

THE INTERTYPE
MOLD SYSTEM

THE INTERTYPE MOLD SYSTEM



*Standardized Molds
For Four-Mold and Six-Mold
Pica-Em System*

December 1940

INTERTYPE CORPORATION, BROOKLYN

*Chicago Los Angeles Boston
San Francisco New Orleans*

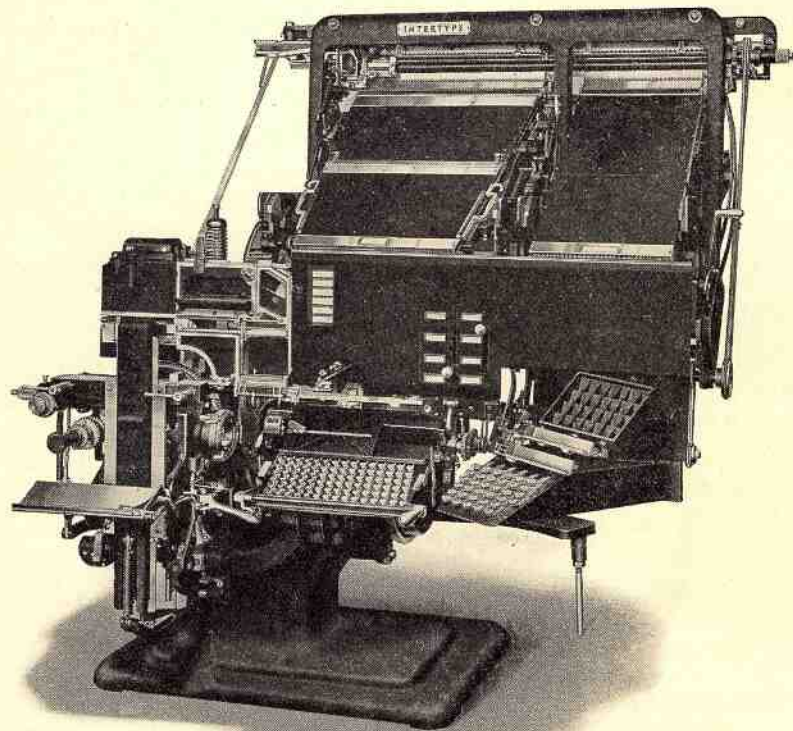

THE UNIVERSAL INTERTYPE

Table of Contents

INTERTYPE STANDARDIZED FOUR-MOLD SYSTEM

Classification of Mold Caps	1
Description of Intertype Molds	1
Universal Adjustable Molds	1
Old-Style Recessed Molds	1
Adjustable Triangular Shelf Molds	3
Newspaper Headletter Triangular Shelf Molds	3
Advertising Figure Molds	5
Changing Mold Caps or Liners	5
Care of the Mold	5
Use of Liners with Intertype Molds	7
Use of First-Elevator Alignment Stop Bar	7

INTERTYPE MOLDS FOR FOUR-MOLD DISK

Straight Matter Composition, 5 to 60 Point	10
Advertising Figure Molds	15
Two-Letter Matrices, 16, 18 and 24 Point	18
High Cap Accent Matrices	20
Normal High Cap Accent Matrices	21
Low Cap Accent Matrices	21
Small Cap Accent Matrices	21
Casting Leads and Spacing Material	24
Ribless Molds	24

INTERTYPE STANDARDIZED SIX-MOLD SYSTEM

Description of Liner Insert Style	25
Description of Linerless Style	27

INTERTYPE MOLDS FOR SIX-MOLD DISK

Solid Slugs, 5 to 14 Point Matrices	27
Recessed Slugs, 10, 12 or 14 Point Matrices	28
Recessed Slugs, 16, 18 or 24 Point One-Letter Matrices	29
Recessed Slugs, 30 or 36 Point Matrices	29
Recessed Slugs, 16, 18 and 24 Point Two-Letter Matrices	29
Recessed Slugs, 42, 48 or 60 Point Matrices	30
Advertising Figure Mold, Recessed Slugs, 10, 12 or 14 Point	30
Advertising Figure Mold, Solid Slugs, 5 to 14 Point	31
Advertising Figure Mold, Recessed Slugs, For 18 and 24 Point Two-Letter Matrices Only	31
Examples of Advertising Figure Work	32

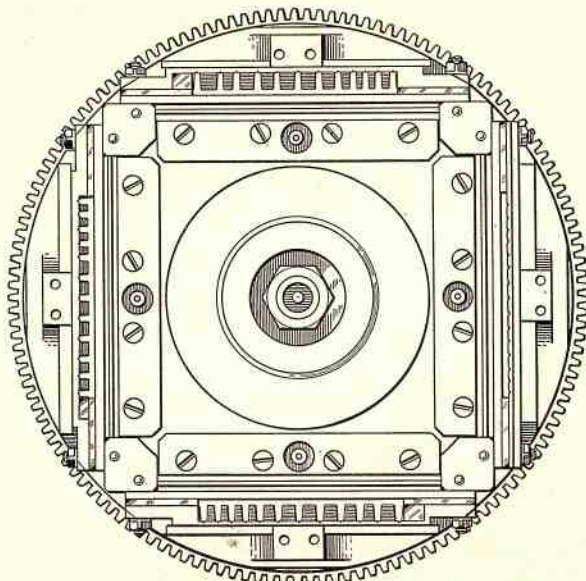

FOUR-MOLD DISK

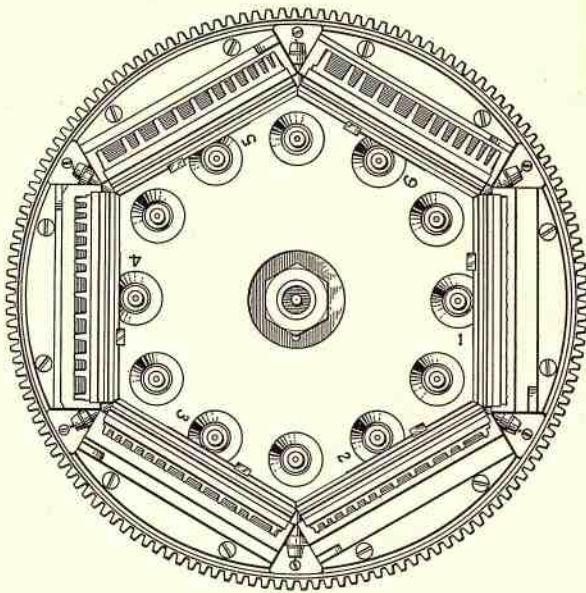

SIX-MOLD DISK

MOLDS FOR INTERTYPE FOUR-POCKET DISK

The exclusive features of Intertype mold design provide a standardized mold system which makes possible a wide range of work with a minimum of equipment. Most Intertype mold caps can be used with *either* one of *two* basic mold bodies; namely,

1. The standard alignment mold body; U-61 for 30 ems and U-1469 for 42 ems. This body can be used with a wide variety of mold caps to produce slugs ranging from 5 points to 36 points in body thickness.

2. The .140" high alignment mold body; U-1645 for 30 ems and U-1599 for 42 ems. This body can be used with various mold caps to produce slugs ranging from 16 points to 48 points in body thickness. A 60 point face (caps only) will cast on a 48 point slug.

Classification of Mold Caps

There are three styles of Intertype recessed mold caps; namely,

1. The old-style recessed mold cap.
2. The adjustable triangular shelf mold cap.
3. The newspaper headletter triangular shelf mold cap.

These caps are classified by letters which indicate the casting range. The same letters are used on all three styles. The part number classifies the style of mold cap. The part number and letter are combined when ordering a mold cap.

Intertype Universal Molds

The universal adjustable mold, Fig. 1, used to cast solid slugs from 5 to 14 points in body thickness, is probably the most commonly used Intertype Mold. It consists mainly of the mold body 1, Fig. 1, the mold cap 2 and two liners 3 and 4. The body 1 is fastened to the mold disk by four screws 5. The liners 3 and 4 are located on the top of the mold body 1 by two dowels 6. The dowel 7 in the mold cap 2 fits into one of the two intersecting holes in the right-hand liner 4 and locates the mold cap accurately in relation to the liners 3 and 4 and the mold body 1. The mold cap 2 is held down upon the liners by nuts 8 and swivel bolts 9.

The right-hand or constant liner 4 varies in thickness only. It is always of the same length. The left-hand liner 3 varies both in thickness and in length.

The thickness of the liners 3 and 4 determines the size of the body of the slug. The length of the left-hand liner 3 determines the length of the slug.

The underside of the mold cap 2 contains tapering grooves 10 which form ribs on the slugs. These ribs are trimmed to accurate body size by the right-hand knife when the slug is ejected from the mold.

Old-Style Recessed Molds

The old-style recessed mold, Fig. 2, can be used for the larger sizes of slugs up to 48 points in body thickness.

These mold caps are recessed various depths which are indicated by the classifying letters. They are recessed to decrease the amount of metal used in

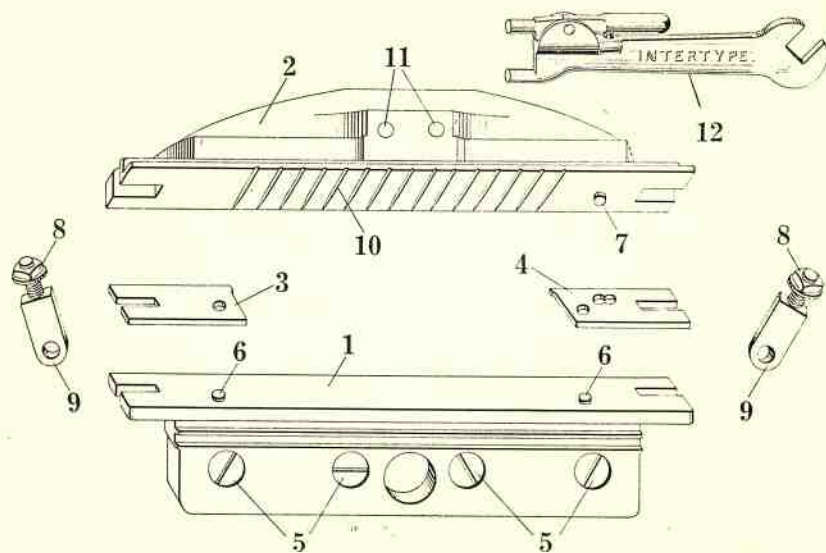

Fig. 1. An Intertype Universal Adjustable Mold

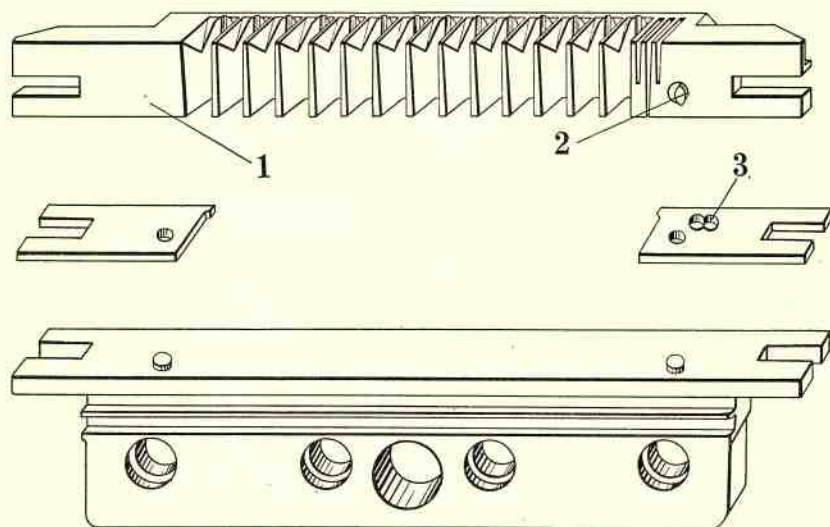

Fig. 2. An Old-Style Recessed Mold

casting slugs and consequently to facilitate the process of "chilling" molten metal into slugs.

The liners used with this mold are identical and interchangeable with the liners used with the universal mold, Fig. 1.

Left-hand liners of various lengths can be used with this mold, making it possible to obtain slugs of lengths varying by half-em measures. This is accomplished by the use of an elliptical dowel 2, Fig. 2, in the mold cap 1. The dowel fits into either of two intersecting holes 3 in the right-hand liner, allowing the mold cap to be shifted from one position to the other in order to align the ribs in the mold cap 1 with the ends of the liners.

Adjustable Triangular Shelf Molds

The adjustable triangular shelf mold, Fig. 3, is recommended for all types of work requiring slugs varying in thickness from 9 to 48 points. These mold caps are recessed various depths which are indicated by the classifying letters.

These molds cast a slug having a solid triangular shelf 2 capable of withstanding dry mat pressure. Needless to say, they are also suitable for printing directly from the slug.

The right-hand liner is identical and interchangeable with the liners used with any other style of mold.

The left-hand liner is the same as liners used with other styles of molds with the exception of a hole 5 which accommodates the dowel 4 and holds the mold liner block 3, whose function is to stop off the type metal at the left hand end of the mold cavity.

Left-hand liners of any length made with this hole can be used interchangeably with any other style of mold.

A mold liner block is supplied with each adjustable triangular shelf mold and it will serve the various length of lines in the particular mold with which it is furnished.

The diagram, Fig. 4, shows the standard rib arrangement No. 2 for the 30-em adjustable triangular shelf mold cap. All full and half-em measures between 3 ems and 30 ems can be cast with the exception of 3½, 5½, 7½, 9½, 11½, 14½, 17½, 20½, 23½, 25½ and 29½ ems. If any of these measures are required, they can be furnished but it is necessary, at the time that one of these measures is ordered, to designate what measure should be sacrificed. For example, should 17½ ems be specified, it is necessary to sacrifice either the 17-em or the 18-em measure.

The diagram, Fig. 5, shows the standard rib arrangement No. 2 for the 42-em adjustable triangular shelf mold cap. The rib arrangement is the same for the first 30 ems of its length as for 30-em mold cap. All full and half-em measures between 3 ems and 42 ems can be cast with the exception of 3½, 5½, 7½, 9½, 11½, 14½, 17½, 20½, 23½, 25½, 29½, 32½, 35½, 38½ and 41½ ems. If any of these measures are required, they can be furnished, but it is necessary, at the time that one of these measures is ordered, to designate what measure should be sacrificed. For example, should 35½ ems be specified, it is necessary to sacrifice either the 35-em measure or the 36-em measure.

Newspaper Headletter Triangular Shelf Molds

These molds are especially intended for use on machines equipped with saws where slugs of maximum length are cast and then cut to size.

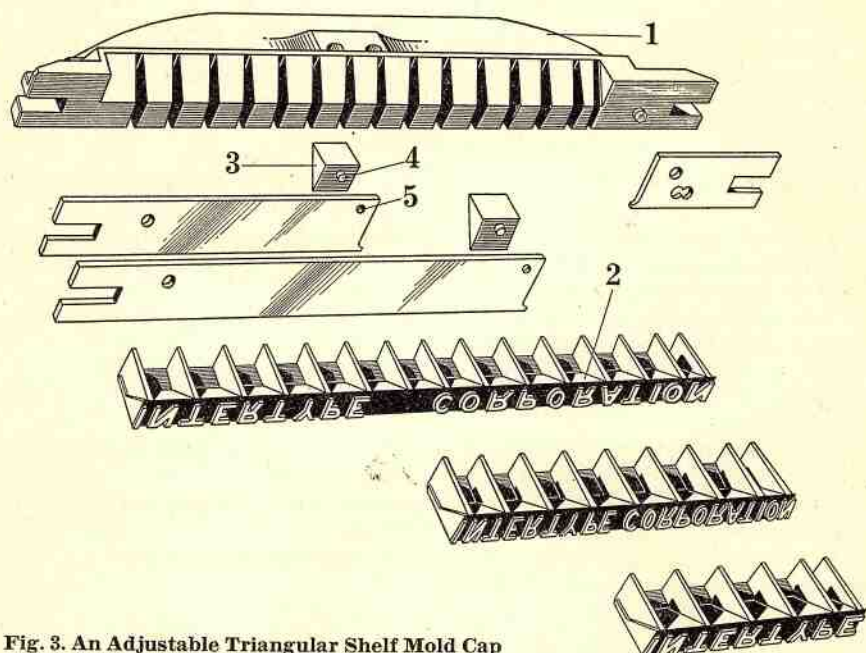
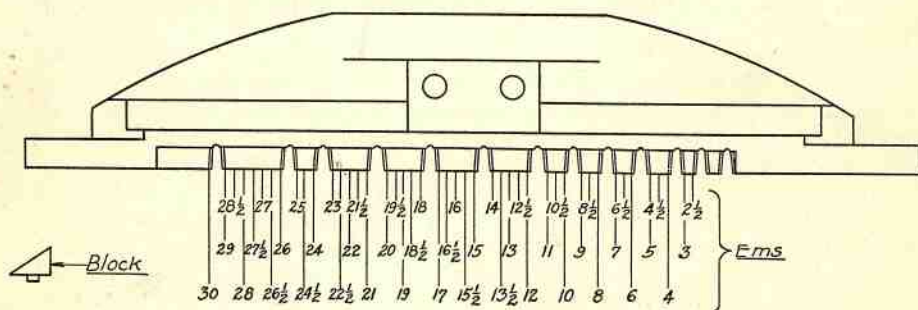

Fig. 3. An Adjustable Triangular Shelf Mold Cap



End View of L.H. Liner and Block

Fig. 4. Standard Rib Arrangement No. 2 for 30-em adjustable triangular shelf and newspaper headletter triangular shelf mold caps, showing length of slugs which can be cast.

They are similar to the adjustable triangular shelf molds in all respects except two; namely,

1. Slugs of maximum length (30 or 42 ems) are cast without the use of the mold liner block.
2. Measures between 27 and 30 ems on a 30-em mold; 39 and 42 ems on a 42-em mold cannot be cast, because the mold liner block is 3 ems long.

Advertising Figure Molds

These molds are made in the solid slug, old-style recessed, adjustable triangular shelf and newspaper headletter triangular shelf styles.

They are used for casting large overhanging display characters on a slug body of smaller sizes. The overhanging characters cast against a wide lip 1, Fig. 7, and are supported by the slug immediately following.

The number of points it is possible to overhang on a mold of this type varies with the width of the lip on the mold cap.

Changing Mold Caps or Liners

To change the mold cap or liners on an Intertype mold, simply loosen nuts 8, Fig. 1, and swing the swivel bolts 9 away from the mold.

The mold cap can then be lifted off by inserting the forked end of the mold cap wrench 12 in the two holes 11 in the mold cap 2.

Remove the liners, wipe off the top of the mold body with a soft rag, insert the new liners and replace the mold cap.

Care of the Mold

Intertype molds are manufactured under rigid standards of precision which insure a high degree of accuracy in all important dimensions of the mold. If molds are used with the care and consideration which fine parts deserve, they will give satisfactory service. Molds are made of carefully tempered steel designed to withstand the normal casting temperature of the type metal. If excessive heat is applied to the mold, however, the temper will be drawn from the parts. For this reason, gas torches should not be used near the mold and *the machine should never be left with the pot mouthpiece against the mold for any length of time.*

After the mold has been in use for a certain length of time, the casting surfaces of the mold body and cap will gradually become coated with a greyish film of oxide. This oxide film, commonly regarded as a detriment, is really of great benefit to the mold because it insures easy ejection of slugs. When the casting surfaces of the mold are new and perfectly clean, the steel has a considerable affinity to type metal. After twenty-five or thirty slugs are cast in rapid succession without permitting the mold to cool, ejection becomes difficult because the type metal adheres closely to the highly finished mold surfaces. It is this metal adhesion which must be prevented. There is a systematic procedure which should be followed for "breaking in" a new mold. When the mold is placed on the mold disk, five to ten slugs should be cast and as soon as ejection becomes difficult, the mold should be permitted to cool for a few minutes. Eight to ten slugs can then be cast and the mold should be permitted to cool again. This process is carried on until the casting surfaces of the mold body and cap take on an oxide discoloration. The discoloration is of a brownish-red color at first and is

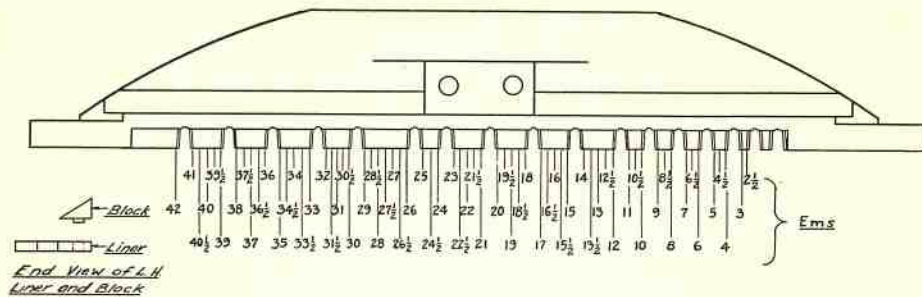

Fig. 5. Standard Rib Arrangement No. 2 for 42-em adjustable triangular shelf and newspaper headletter triangular shelf mold caps, showing length of slugs which can be cast.

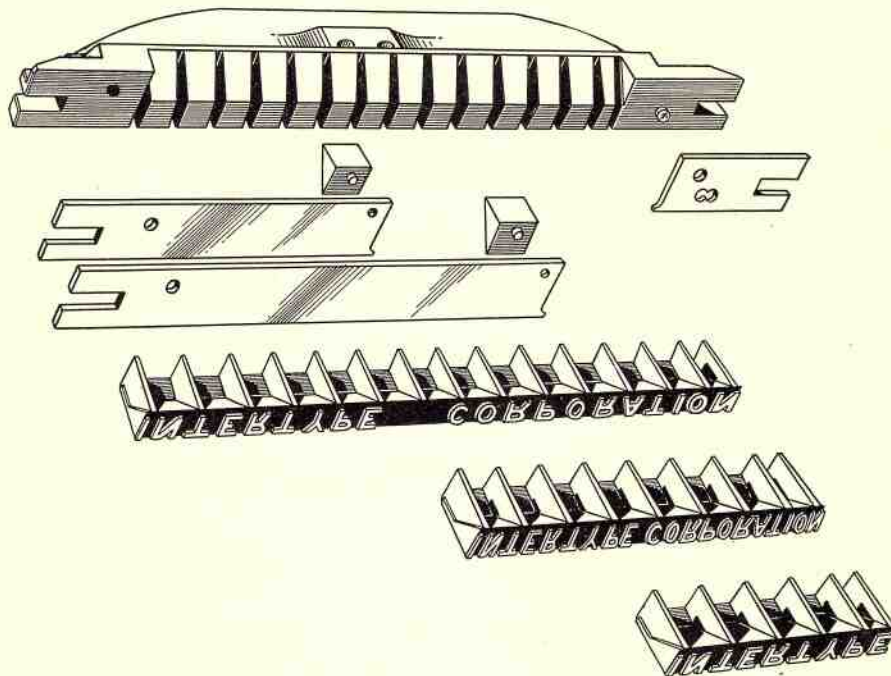

Fig. 6. A Newspaper Headletter Triangular Shelf Mold Cap

usually obtained after about fifty slugs have been cast by the gradual process described above. As additional slugs are cast, the oxide film becomes greyish in color and extends from the back of the mold to the front. Once this film is formed, it will act as an insulating layer between the mold surfaces and the slugs and ejection will be easy from then on.

It is sometimes necessary to polish the mold in order to remove small particles of metal which adhere to the mold body and cap. When mold polish is used, it should be applied to the mold surfaces with a flat pine stick. The stick should be moved in circular strokes and should be held flat on the surface being polished. Tilting the stick will tend to round the edges of the mold. After the parts have been cleaned, remove the polish with a cloth. Most of the oxide film formed on the casting surfaces of the mold will be removed when mold polish is used. Consequently before the mold is placed in use again, it should be subjected to the gradual "breaking in" process described above until a new film is formed.

Use of Liners with Intertype Molds

The exclusive features of Intertype mold design permit the interchangeable use of the standard right-hand (U-327) liner in any mold manufactured by Intertype for the four-mold disk.

The left-hand (U-328) liner is interchangeable in the universal adjustable, the old-style recessed, and for casting 30 ems in the newspaper headletter triangular shelf molds.

The left-hand (U-3157) liner is interchangeable in any mold manufactured by Intertype. A mold liner block (U-3155) is used in conjunction with this left-hand liner when the liner is used in either the adjustable triangular shelf or newspaper headletter triangular shelf styles of molds.

The casting range of each Intertype mold cap is very plainly stamped on the cap. This casting range, in most cases, is based on the use of a minimum liner of 6 points and a maximum liner of 12 points. However, it is possible to use a 5 point liner with mold caps but, under no circumstances, should any liner less than 5 points be used unless a special ejector blade is purchase.

Use of First-Elevator Alignment Stop Bar

A new style first-elevator alignment stop bar (or filling-in piece, as it is often called in the trade) indicator plate 4, Fig. 8, is mounted on the front plate of the delivery channel on 30-em machines. Three numbers stamped on the indicator plate correspond with the three positions of the stop bar: normal, headletter and high alignment. The pointer 5 on the stop bar 6 registers with the three numbers on the indicator plate and indicates plainly the position of the stop bar.

When the stop bar is placed in position 1 on the indicator plate, the first elevator banks on the stop bar at point 1 and is held in normal alignment position with respect to the mold.

When the stop bar is placed in position 2 on the indicator plate, the first elevator banks on the stop bar at point 2 and is held in the headletter alignment position with respect to the mold.

When the stop bar is placed in position 3 on the indicator plate, the first elevator banks on the stop bar at point 3 and is held in the high alignment position with respect to the mold.

Position 1 on the indicator plate is commonly referred to as the normal or No. 1 position; position 2 is referred to as the auxiliary, headletter or No. 2

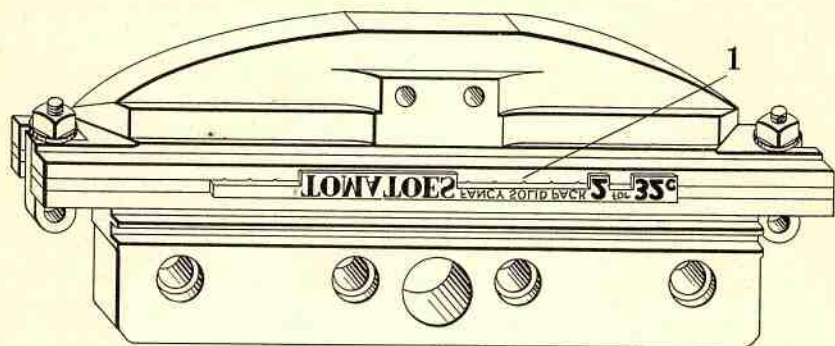

Fig. 7. An Advertising Figure Mold, Assembled

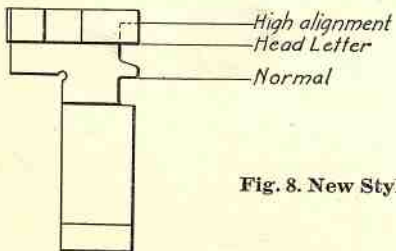
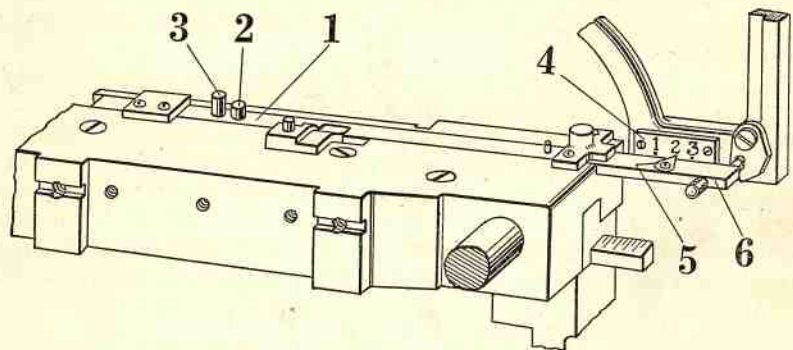

Fig. 8. New Style First-Elevator Alignment Stop Bar

position; and position 3 is referred to as the high alignment, .140" alignment or No. 3 position.

Any reference to the position of the mold when casting in this booklet refers to the position of the first-elevator alignment stop bar, or, as it is commonly termed, the filling-in piece.

Following is given a list of the nine basic types of matrices with the position of the alignment stop bar in each case:

	<i>Alignment Stop Bar Pointer</i>
5 to 14 point, two-letter, regular position	No. 1
5 to 14 point, two-letter, auxiliary position	*No. 2
18 and 24 point, two-letter, regular position	No. 1
18 and 24 point, two-letter, auxiliary position	No. 3
18 to 36 point, one-letter	No. 2
42 to 60 point, one-letter	No. 3
18 to 30 point, advertising figures	No. 1
36, 42 and 48 point, advertising figures	†No. 2
60 point, advertising figures	No. 3

Changes Necessary in the First-Elevator Alignment Stop Bar When Using Molds for Normal High Cap or High Cap Accent Matrices

When ordering molds for use with Normal High Cap Accent matrices or High Cap Accent matrices for outstanding machines, which machines have not previously been equipped with molds for these matrices, it is necessary to change a pin or pins in the first-elevator alignment stop bar and in the first-elevator vise automatic stop.

Therefore, when ordering molds for these matrices, specify what molds are now on the machine, what molds will be replaced by the accent molds, serial number of the machine, and what molds, if any, will be used on the machine in addition to the molds for the normal high cap and high cap accent matrices.

With this information, we can advise what pins are needed and how to install them.

When a new machine is shipped from the factory, and is equipped with molds for use with either the normal high cap or high cap accent matrices, the correct pins for the first-elevator alignment stop bar and the first-elevator vise automatic stop are on the machine.

On pages 10 to 24 of this book are shown all the Intertype mold caps for the four-pocket disk. With each cap the part numbers, the casting range for straight matter and advertising figure work, and range of liners is given.

*The auxiliary characters on 5 to 14 point two-letter matrices may be cast with the stop bar in No. 1 position if the matrices have been assembled on the duplex rail.

†There are some 42 and 48 point advertising figure faces which cast in the .140" high alignment or No. 3 position.

For 5 to 14 Point Faces

UNIVERSAL CAP

For Solid Slug



Part Numbers

Name of Part	30-em Mold	42-em Mold
Mold, Assembled	U-341	U-1470
Mold Cap	U-329	U-1468
Mold Body	U- 61	U-1469
Right-Hand Liner	U-327	U- 327
Left-Hand Liner	U-328	U- 328

Range of Liners for Universal Cap

Liner Size	Slug Size	Liner Size	Slug Size
5 point for 5 point	10 point for 10 point		
6 point for 6 point	11 point for 11 point		
7 point for 7 point	12 point for 12 point		
8 point for 8 point	13 point for 13 point		
9 point for 9 point	14 point for 14 point		

Universal Cap Advertising Figure Work

Adv. Figure	Kind of Work
24 point	two lines of 12 point
18 point	two lines of 8 point
14 point	two lines of 6 point
12 point	two lines of 5 point

For 8 to 14 Point Faces

OLD-STYLE N CAP

Recessed 3 Points

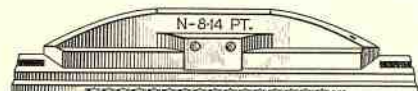

Part Numbers

Name of Part	30-em Mold	42-em Mold
Mold, Assembled	U-341N	U-1470N
Mold Cap	U-329N	U-1468N
Mold Body	U- 61	U-1469
Right-Hand Liner	U-327	U- 327
Left-Hand Liner	U-328	U- 328

Range of Liners for N Cap

Liner Size	Slug Size	Liner Size	Slug Size
5 point for 8 point	9 point for 12 point		
6 point for 9 point	10 point for 13 point		
7 point for 10 point	11 point for 14 point		
8 point for 11 point			

N Cap Advertising Figure Work

Adv. Figure	Kind of Work
24 point	two lines of 10 point
18 point	two lines of 8 point

*Mold Liner Block used only for measures up to 27 ems on 30-em mold, and up to 39 ems on 42-em mold. Either Left-Hand Liner U-328 or U-3157 can be used to cast maximum length of slug on 30 or 42-em mold.

See pages 32 to 38 for examples of advertising figure work

For 9 to 14 Point Faces

OLD-STYLE A CAP

Recessed 4 Points



Part Numbers

Name of Part	30-em Mold	42-em Mold
Mold, Assembled	U-341A	U-1470A
Mold Cap	U-329A	U-1468A
Mold Body	U- 61	U-1469
Right-Hand Liner	U-327	U- 327
Left-Hand Liner	U-328	U- 328

ADJUSTABLE TRIANGULAR SHELF STYLE A CAP

Recessed 4 Points

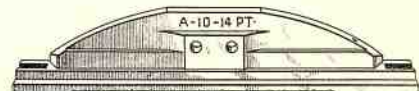

Part Numbers

Name of Part	30-em Mold	42-em Mold
Mold, Assembled	U-3150A	U-3212A
Mold Cap	U-3154A	U-3213A
Mold Body	U- 61	U-1469
Right-Hand Liner	U- 327	U- 327
Left-Hand Liner	U-3157	U-3157
Mold Liner Block	U-3155A	U-3155A

NEWSPAPER HEADLETTER SHELF STYLE A CAP

Recessed 4 Points



Part Numbers

Name of Part	30-em Mold	42-em Mold
Mold, Assembled	U-2470A	U-3965A
Mold Cap	U-2467A	U-3966A
Mold Body	U- 61	U-1469
Right-Hand Liner	U- 327	U- 327
Left-Hand Liner	*U-3157	*U-3157
Mold Liner Block	*U-3155A	*U-3155A

Range of Liners for All A Caps

Liner Size	Slug Size	Liner Size	Slug Size
5 point for 9 point	8 point for 12 point		
6 point for 10 point	9 point for 13 point		
7 point for 11 point	10 point for 14 point		

For 11 to 18 Point Faces

OLD-STYLE B CAP

Recessed 6 Points

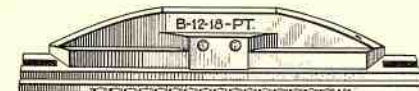

Part Numbers

Name of Part	30-em Mold	42-em Mold
Mold, Assembled	U-341B	U-1470B
Mold Cap	U-329B	U-1468B
Mold Body	U- 61	U-1469
Right-Hand Liner	U-327	U- 327
Left-Hand Liner	U-328	U- 328

ADJUSTABLE TRIANGULAR SHELF STYLE B CAP

Recessed 6 Points



Part Numbers

Name of Part	30-em Mold	42-em Mold
Mold, Assembled	U-3150B	U-3212B
Mold Cap	U-3154B	U-3213B
Mold Body	U- 61	U-1469
Right-Hand Liner	U- 327	U- 327
Left-Hand Liner	U-3157	U-3157
Mold Liner Block	U-3155B	U-3155B

NEWSPAPER HEADLETTER SHELF STYLE B CAP

Recessed 6 Points



Part Numbers

Name of Part	30-em Mold	42-em Mold
Mold, Assembled	U-2470B	U-3965B
Mold Cap	U-2467B	U-3966B
Mold Body	U- 61	U-1469
Right-Hand Liner	U- 327	U- 327
Left-Hand Liner	*U-3157	*U-3157
Mold Liner Block	*U-3155B	*U-3155B

Range of Liners for All B Caps

Liner Size	Slug Size	Liner Size	Slug Size
5 point for 11 point	9 point for 15 point		
6 point for 12 point	10 point for 16 point		
7 point for 13 point	11 point for 17 point		
8 point for 14 point	12 point for 18 point		

*Mold Liner Block used only for measures up to 27 ems on 30-em mold, and up to 39 ems on 42-em mold. Either Left-Hand Liner U-328 or U-3157 can be used to cast maximum length of slug on 30 or 42-em mold.

See pages 32 to 38 for examples of advertising figure work

For 18 to 24 Point Faces

OLD-STYLE C CAP

Recessed 12 Points



Part Numbers

Name of Part	30-em Mold	42-em Mold
Mold, Assembled	U-341C	U-1470C
Mold Cap	U-329C	U-1468C
Mold Body	U- 61	U-1469
Right-Hand Liner	U-327	U- 327
Left-Hand Liner	U-328	U- 328

ADJUSTABLE TRIANGULAR SHELF STYLE C CAP

Recessed 12 Points

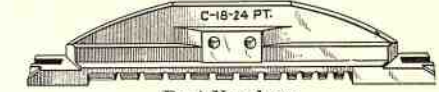

Part Numbers

Name of Part	30-em Mold	42-em Mold
Mold, Assembled	U-3150C	U-3212C
Mold Cap	U-3154C	U-3213C
Mold Body	U- 61	U-1469
Right-Hand Liner	U- 327	U- 327
Left-Hand Liner	U-3157	U-3157
Mold Liner Block	U-3155C	U-3155C

NEWSPAPER HEADLETTER SHELF STYLE C CAP

Recessed 12 Points



Part Numbers

Name of Part	30-em Mold	42-em Mold
Mold, Assembled	U-2470C	U-3965C
Mold Cap	U-2467C	U-3966C
Mold Body	U- 61	U-1469
Right-Hand Liner	U- 327	U- 327
Left-Hand Liner	*U-3157	*U-3157
Mold Liner Block	*U-3155C	*U-3155C

Range of Liners for All C Caps

Liner Size	Slug Size	Liner Size	Slug Size
5 point for 17 point	9 point for 21 point		
6 point for 18 point	10 point for 22 point		
7 point for 19 point	11 point for 23 point		
8 point for 20 point	12 point for 24 point		

C Cap Advertising Figure Work

Adv. Figure	Kind of Work
42 Point	two lines of 18 point
36 Point	two lines of 18 point

For 24 to 30 Point Faces

OLD-STYLE D CAP

Recessed 18 Points



Part Numbers

Name of Part	30-em Mold	42-em Mold
Mold, Assembled	U-341D	U-1470D
Mold Cap	U-329D	U-1468D
Mold Body	U- 61	U-1469
Right-Hand Liner	U-327	U- 327
Left-Hand Liner	U-328	U- 328

ADJUSTABLE TRIANGULAR SHELF STYLE D CAP

Recessed 18 Points



Part Numbers

Name of Part	30-em Mold	42-em Mold
Mold, Assembled	U-3150D	U-3212D
Mold Cap	U-3154D	U-3213D
Mold Body	U- 61	U-1469
Right-Hand Liner	U- 327	U- 327
Left-Hand Liner	U-3157	U-3157
Mold Liner Block	U-3155D	U-3155D

NEWSPAPER HEADLETTER SHELF STYLE D CAP

Recessed 18 Points



Part Numbers

Name of Part	30-em Mold	42-em Mold
Mold, Assembled	U-2470D	U-3965D
Mold Cap	U-2467D	U-3966D
Mold Body	U- 61	U-1469
Right-Hand Liner	U- 327	U- 327
Left-Hand Liner	*U-3157	*U-3157
Mold Liner Block	*U-3155D	*U-3155D

Range of Liners for All D Caps

Liner Size	Slug Size	Liner Size	Slug Size
5 point for 23 point	9 point for 27 point		
6 point for 24 point	10 point for 28 point		
7 point for 25 point	11 point for 29 point		
8 point for 26 point	12 point for 30 point		

*Mold Liner Block used only for measures up to 27 ems on 30-em mold, and up to 39 ems on 42-em mold. Either Left-Hand Liner U-328 or U-3157 can be used to cast maximum length of slug on 30 or 42-em mold.

For 30 to 36 Point Faces

OLD-STYLE E CAP

Recessed 24 Points



Part Numbers

Name of Part	30-em Mold	42-em Mold
Mold, Assembled	U-341E	U-1470E
Mold Cap	U-329E	U-1468E
Mold Body	U- 61	U-1469
Right-Hand Liner	U-327	U- 327
Left-Hand Liner	U-328	U- 328

ADJUSTABLE TRIANGULAR SHELF STYLE E CAP

Recessed 24 Points

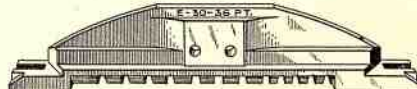

Part Numbers

Name of Part	30-em Mold	42-em Mold
Mold, Assembled	U-3150E	U-3212E
Mold Cap	U-3154E	U-3213E
Mold Body	U- 61	U-1469
Right-Hand Liner	U- 327	U- 327
Left-Hand Liner	U-3157	U-3157
Mold Liner Block	U-3155E	U-3155E

NEWSPAPER HEADLETTER SHELF STYLE E CAP

Recessed 24 Points



Part Numbers

Name of Part	30-em Mold	42-em Mold
Mold, Assembled	U-2470E	U-3965E
Mold Cap	U-2467E	U-3966E
Mold Body	U- 61	U-1469
Right-Hand Liner	U- 327	U- 327
Left-Hand Liner	*U-3157	*U-3157
Mold Liner Block	*U-3155E	*U-3155E

Range of Liners for All E Caps

Liner Size	Slug Size	Liner Size	Slug Size
5 point for 29 point	9 point for 33 point		
6 point for 30 point	10 point for 34 point		
7 point for 31 point	11 point for 35 point		
8 point for 32 point	12 point for 36 point		

*Mold Liner Block used only for measures up to 27 ems on 30-em mold, and up to 39 ems on 42-em mold. Either Left-Hand Liner U-328 or U-3157 can be used to cast maximum length of slug on 30 or 42-em mold.

For 36 Point Faces

ADJUSTABLE TRIANGULAR SHELF STYLE P CAP

Recessed 30 Points



Part Numbers

Name of Part	30-em Mold	42-em Mold
Mold, Assembled	U-3150P	U-3212P
Mold Cap	U-3154P	U-3213P
Mold Body	U- 61	U-1469
Right-Hand Liner	U- 327	U- 327
Left-Hand Liner	U-3157	U-3157
Mold Liner Block	U-3155P	U-3155P

NEWSPAPER HEADLETTER SHELF STYLE P CAP

Recessed 30 Points

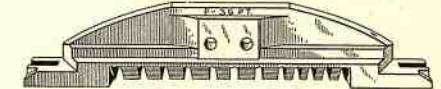

Part Numbers

Name of Part	30-em Mold	42-em Mold
Mold, Assembled	U-2470P	U-3965P
Mold Cap	U-2467P	U-3966P
Mold Body	U- 61	U-1469
Right-Hand Liner	U- 327	U- 327
Left-Hand Liner	*U-3157	*U-3157
Mold Liner Block	*U-3155P	*U-3155P

Use 6 point liners only for 36 point slug

For 36 to 42 Point Faces

ADJUSTABLE TRIANGULAR SHELF STYLE P CAP

Recessed 30 Points



.140" High Alignment

Part Numbers

Name of Part	30-em Mold	42-em Mold
Mold, Assembled	U-3378P	U-3379P
Mold Cap	U-3154P	U-3213P
Mold Body	U-1645	U-1599
Right-Hand Liner	U- 327	U- 327
Left-Hand Liner	U-3157	U-3157
Mold Liner Block	U-3155P	U-3155P

NEWSPAPER HEADLETTER SHELF STYLE P CAP

Recessed 30 Points

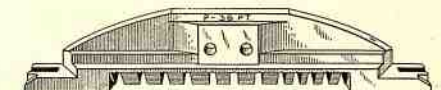

.140" High Alignment

Part Numbers

Name of Part	30-em Mold	42-em Mold
Mold, Assembled	U-2469P	U-4638P
Mold Cap	U-2467P	U-3966P
Mold Body	U-1645	U-1599
Right-Hand Liner	U- 327	U- 327
Left-Hand Liner	*U-3157	*U-3157
Mold Liner Block	*U-3155P	*U-3155P

Range of Liners for 36 to 42 Point Caps

Liner Size	Slug Size	Liner Size	Slug Size
5 point for 35 point	9 point for 39 point		
6 point for 36 point	10 point for 40 point		
7 point for 37 point	11 point for 41 point		
8 point for 38 point	12 point for 42 point		

*Mold Liner Block used only for measures up to 27 ems on 30-em mold, and up to 39 ems on 42-em mold. Either Left-Hand Liner U-328 or U-3157 can be used to cast maximum length of slug on 30 or 42-em mold.

For 42, 48 and 60 Point Faces

60 point (caps only) casts on 48 point slug

ADJUSTABLE TRIANGULAR SHELF STYLE Q CAP

Recessed 36 Points



.140" High Alignment

Part Numbers

Name of Part	30-em Mold	42-em Mold
Mold, Assembled	U-3378Q	U-3379Q
Mold Cap	U-3154Q	U-3213Q
Mold Body	U-1645	U-1599
Right-Hand Liner	U- 327	U- 327
Left-Hand Liner	U-3157	U-3157
Mold Liner Block	U-3155Q	U-3155Q

With the Q cap the following sizes may be cast together on one slug (not overhang).

- 60 pt. with 36 pt. one-letter on 48 pt. slug
- 60 pt. with 30 pt. one-letter on 48 pt. slug
- 60 pt. with 24 pt. one-letter on 48 pt. slug
- 60 pt. with 18 pt. one-letter on 48 pt. slug
- 48 pt. with 36 pt. one-letter on 48 pt. slug
- 48 pt. with 30 pt. one-letter on 48 pt. slug
- 48 pt. with 24 pt. one-letter on 48 pt. slug
- 48 pt. with 18 pt. one-letter on 48 pt. slug
- 42 pt. with 24 pt. one-letter on 42 pt. slug
- 42 pt. with 18 pt. one-letter on 42 pt. slug

See pages 32 to 38 for examples of advertising figure work

THE INTERTYPE AUTOSPACER which quads and centers lines automatically, is specified by nearly all buyers of modern Intertypes. Why? *Because the Autospace saves money!* The following comments, written by Autospace users to a prospective buyer, are typical of many: "The Quadder is undoubtedly the greatest labor-saving device ever installed on typesetting machines. It has never given us a bit of trouble, and it operates perfectly." Another user says: "We fully indorse the Quadder, as it permits the setting of display with almost 'hang-the-elevator' speed. It is an integral part of the machine, and will pay its own way in a short period of time. The construction and operation of the Quadder is simplicity itself. We have never had a moment's trouble with it." Note that both of these comments mention (1) *simplicity of operation* and (2) *trouble-free service*. These features are particularly important. *Investigate!*

NEWSPAPER HEADLETTER SHELF STYLE Q CAP

Recessed 36 Points



.140" High Alignment

Part Numbers

Name of Part	30-em Mold	42-em Mold
Mold, Assembled	U-2469Q	U-4638Q
Mold Cap	U-2467Q	U-3966Q
Mold Body	U-1645	U-1599
Right-Hand Liner	U- 327	U- 327
Left-Hand Liner	*U-3157	*U-3157
Mold Liner Block	*U-3155Q	*U-3155Q

*Mold Liner Block used only for measures up to 27 ems on 30-em mold, and up to 39 ems on 42-em mold. Either Left-Hand Liner U-328 or U-3157 can be used to cast maximum length of slug on 30 or 42-em mold.

Range of Liners for All Q Caps

Liner Size	Slug Size	Liner Size	Slug Size
5 point for 41 point	9 point for 45 point		
6 point for 42 point	10 point for 46 point		
7 point for 43 point	11 point for 47 point		
8 point for 44 point	12 point for 48 point		

For Advertising Figures up to 24 Point

M CAP

Solid Slug, 5 to 10 Point

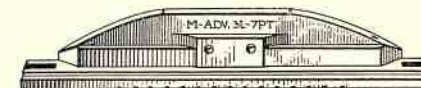

Part Numbers

Name of Part	30-em Mold	42-em Mold
Mold, Assembled	U-341M	U-1470M
Mold Cap	U-329M	U-1468M
Mold Body	U- 61	U-1469
Right-Hand Liner	U-327	U- 327
Left-Hand Liner	U-328	U- 328

Range of Liners for M Cap

Liner Size	Slug Size	Liner Size	Slug Size
5 point for 5 point	8 point for 8 point		
6 point for 6 point	9 point for 9 point		
7 point for 7 point	10 point for 10 point		

Maximum Overhang..... 14 points
 Maximum Liners..... 10 points
 All Matrices in the Auxiliary Position

The M cap may also be used to cast straight matter (auxiliary position only) work of 5 to 10 point using 5 to 10 point liners.

M Cap Advertising Figure Work

Adv. Figure	Kind of Work
24 point.....	two lines of 10 point
24 point.....	three lines of 7 point
24 point.....	three lines of 6 point
18 point.....	two lines of 8 point

For Advertising Figures up to 30 Point

F CAP

Solid Slug, 5 to 12 Point



Part Numbers

Name of Part	30-em Mold	42-em Mold
Mold, Assembled	U-341F	U-1470F
Mold Cap	U-329F	U-1468F
Mold Body	U- 61	U-1469
Right-Hand Liner	U-327	U- 327
Left-Hand Liner	U-328	U- 328

Maximum Overhang..... 12 points
 Maximum Liners..... 12 points

The F cap may also be used to cast straight matter work of 6 to 12 points using 6 to 12 point liners.

F Cap Advertising Figure Work

Adv. Figure	Kind of Work
30 point.....	two lines of 12 point
24 point.....	two lines of 10 point
24 point.....	two lines of 9 point
24 point.....	three lines of 7 point
18 point.....	three lines of 6 point
18 point.....	two lines of 8 point
18 point.....	three lines of 5 point
12 point.....	two lines of 5 point
14 point.....	two lines of 6 point

See pages 32 to 38 for examples of advertising figure work

Range of Liners for F Cap

Liner Size	Slug Size	Liner Size	Slug Size
5 point for 5 point	9 point for 9 point		
6 point for 6 point	10 point for 10 point		
7 point for 7 point	11 point for 11 point		
8 point for 8 point	12 point for 12 point		

For Advertising Figures up to 30 Point

H CAP

Solid Slug, 5 to 8 Point



Part Numbers

Name of Part	30-em Mold	42-em Mold
Mold, Assembled	U-341H	U-1470H
Mold Cap	U-329H	U-1468H
Mold Body	U- 61	U-1469
Right-Hand Liner	U-327	U- 327
Left-Hand Liner	U-328	U- 328

Maximum Overhang..... 16 points
Maximum Liners..... 8 points

Range of Liners for H Cap

Liner Size	Slug Size	Liner Size	Slug Size
5 point for 5 point		7 point for 7 point	
6 point for 6 point		8 point for 8 point	

The H cap may also be used to cast straight matter work of 5 to 8 point using 5 to 8 point liners.

H Cap Advertising Figure Work

Adv. Figure	Kind of Work
30 point.....	three lines of 8 point
24 point.....	three lines of 8 point
24 point.....	three lines of 7 point
24 point.....	four lines of 6 point
24 point.....	four lines of 5 point
18 point.....	two lines of 8 point
18 point.....	three lines of 5 point

OLD-STYLE G CAP

Recessed 4 Points

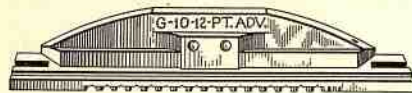

Part Numbers

Name of Part	30-em Mold	42-em Mold
Mold, Assembled	U-341G	U-1470G
Mold Cap	U-329G	U-1468G
Mold Body	U- 61	U-1469
Right-Hand Liner	U-327	U- 327
Left-Hand Liner	U-328	U- 328

*Mold Liner Block used only for measures up to 27 ems on 30-em mold, and up to 39 ems on 42-em mold. Either Left-Hand Liner U-328 or U-3157 can be used to cast maximum length of slug on 30 or 42-em mold.

See pages 32 to 38 for examples of advertising figure work

ADJUSTABLE TRIANGULAR SHELF STYLE G CAP

Recessed 4 Points



Part Numbers

Name of Part	30-em Mold	42-em Mold
Mold, Assembled	U-3150G	U-3212G
Mold Cap	U-3154G	U-3213G
Mold Body	U- 61	U-1469
Right-Hand Liner	U- 327	U- 327
Left-Hand Liner	U-3157	U-3157
Mold Liner Block	U-3155G	U-3155G

NEWSPAPER HEADLETTER SHELF STYLE G CAP

Recessed 4 Points



Part Numbers

Name of Part	30-em Mold	42-em Mold
Mold, Assembled	U-2470G	U-3965G
Mold Cap	U-2467G	U-3966G
Mold Body	U- 61	U-1469
Right-Hand Liner	U- 327	U- 327
Left-Hand Liner	*U-3157	*U-3157
Mold Liner Block	*U-3155G	*U-3155G

Maximum Overhang..... 12 points
Maximum Liners..... 8 points

Range of Liners for All G Caps

Liner Size	Slug Size	Liner Size	Slug Size
5 point for 9 point		7 point for 11 point	
6 point for 10 point		8 point for 12 point	

The G cap may be used to cast straight matter work of 9 to 12 points using 5 to 8 point liners.

G Cap Advertising Figure Work

Adv. Figure	Kind of Work
30 point.....	two lines of 12 point
24 point.....	two lines of 10 point

For Advertising Figures up to 42 Point

I CAP

Solid Slug, 5 to 12 Point

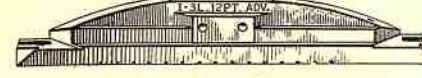

Part Numbers

Name of Part	30-em Mold	42-em Mold
Mold, Assembled	U-341I	U-1470I
Mold Cap	U-329I	U-1468I
Mold Body	U- 61	U-1469
Right-Hand Liner	U-327	U- 327
Left-Hand Liner	U-328	U- 328

Maximum Overhang..... 24 points
Maximum Liners..... 12 points
All Matrices in the Auxiliary Position

Range of Liners for I Cap

Liner Size	Slug Size	Liner Size	Slug Size
5 point for 5 point		9 point for 9 point	
6 point for 6 point		10 point for 10 point	
7 point for 7 point		11 point for 11 point	
8 point for 8 point		12 point for 12 point	

The I cap may also be used to cast straight matter work (auxiliary position) of 5 to 12 points using 5 to 12 point liners.

I Cap Advertising Figure Work

Adv. Figure	Kind of Work
42 point.....	three lines of 12 point
42 point.....	four lines of 9 point
42 point.....	five lines of 7 point
42 point.....	six lines of 6 point
36 point.....	three lines of 10 point
36 point.....	five lines of 6 point
30 point.....	four lines of 6 point
24 point.....	three lines of 7 point

ADJUSTABLE TRIANGULAR SHELF STYLE J CAP

Recessed 6 Points



Part Numbers

Name of Part	30-em Mold	42-em Mold
Mold, Assembled	U-3150J	U-3212J
Mold Cap	U-3154J	U-3213J
Mold Body	U- 61	U-1469
Right-Hand Liner	U- 327	U- 327
Left-Hand Liner	U-3157	U-3157
Mold Liner Block	U-3155J	U-3155J

NEWSPAPER HEADLETTER SHELF STYLE J CAP

Recessed 6 Points

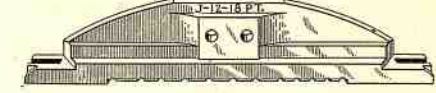

Part Numbers

Name of Part	30-em Mold	42-em Mold
Mold, Assembled	U-2470J	U-3965J
Mold Cap	U-2467J	U-3966J
Mold Body	U- 61	U-1469
Right-Hand Liner	U- 327	U- 327
Left-Hand Liner	*U-3157	*U-3157
Mold Liner Block	*U-3155J	*U-3155J

Maximum Overhang..... 18 points
Maximum Liners..... 12 points

Range of Liners for All J Caps

Liner Size	Slug Size	Liner Size	Slug Size
5 point for 11 point		9 point for 15 point	
6 point for 12 point		10 point for 16 point	
7 point for 13 point		11 point for 17 point	
8 point for 14 point		12 point for 18 point	

The J cap may also be used to cast straight matter work (auxiliary position only) of 11 to 18 points using 5 to 12 point liners.

J Cap Advertising Figure Work

Adv. Figure	Kind of Work
42 point.....	two lines of 18 point
36 point.....	two lines of 16 point
36 point.....	two lines of 14 point
30 point.....	two lines of 12 point

All Matrices in the Auxiliary Position

OLD STYLE J CAP

Recessed 6 Points

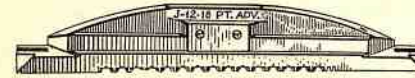

Part Numbers

Name of Part	30-em Mold	42-em Mold
Mold, Assembled	U-341J	U-1470J
Mold Cap	U-329J	U-1468J
Mold Body	U- 61	U-1469
Right-Hand Liner	U-327	U- 327
Left-Hand Liner	U-328	U- 328

*Mold Liner Block used only for measures up to 27 ems on 30-em mold, and up to 39 ems on 42-em mold. Either Left-Hand Liner U-328 or U-3157 can be used to cast maximum length of slug on 30 or 42-em mold.

See pages 32 to 38 for examples of advertising figure work

For 16 Point Two-Letter Faces

ADJUSTABLE TRIANGULAR SHELF STYLE B CAP

Recessed 6 Points



.140" high alignment
Made only for 30 ems

Part Numbers	
Name of Part	30-em Mold
Mold, Assembled	U-4128
Mold Cap	U-3154B
Mold Body	U-1645
Right-Hand Liner	U- 327
Left-Hand Liner	U-3157
Mold Liner Block	U-3155B

Use 10 point liners for 16 point slug

For 18 Point Two-Letter Faces

ADJUSTABLE TRIANGULAR SHELF STYLE

Recessed 12 Points



.140" high alignment

Part Numbers		
Name of Part	30-em Mold	42-em Mold
Mold, Assembled	U-3948	U-3968
Mold Cap	U-3947	U-3969
Mold Body	U-1645	U-1599
Right-Hand Liner	U- 327	U- 327
Left-Hand Liner	U-3157	U-3157
Mold Liner Block	U-3155C	U-3155C

Use 6 point liners for 18 point slug

NEWSPAPER HEADLETTER SHELF STYLE

Recessed 12 Points



.140" high alignment

Part Numbers		
Name of Part	30-em Mold	42-em Mold
Mold, Assembled	U-3985	U-3991
Mold Cap	U-3988	U-3994
Mold Body	U-1645	U-1599
Right-Hand Liner	U- 327	U- 327
Left-Hand Liner	*U-3157	*U-3157
Mold Liner Block	*U-3155C	*U-3155C

For 18 and 24 Point Two-Letter Faces

ADJUSTABLE TRIANGULAR SHELF STYLE

Recessed 12 Points



.140" high alignment

Part Numbers		
Name of Part	30-em Mold	42-em Mold
Mold, Assembled	U-3952	U-3970
Mold Cap	U-3951	U-3971
Mold Body	U-1645	U-1599
Right-Hand Liner	U- 327	U- 327
Left-Hand Liner	U-3157	U-3157
Mold Liner Block	U-3155C	U-3155C

Use 6 point liners for 18 point slug and 12 point liners for 24 point slug

NEWSPAPER HEADLETTER SHELF STYLE

Recessed 12 Points



.140" high alignment

Part Numbers		
Name of Part	30-em Mold	42-em Mold
Mold, Assembled	U-3986	U-3992
Mold Cap	U-3989	U-3995
Mold Body	U-1645	U-1599
Right-Hand Liner	U- 327	U- 327
Left-Hand Liner	*U-3157	*U-3157
Mold Liner Block	*U-3155C	*U-3155C

*Mold Liner Block used only for measures up to 27 ems on 30-em mold, and up to 39 ems on 42-em mold. Either Left-Hand Liner U-328 or U-3157 can be used to cast maximum length of slug on 30 or 42-em mold.

For 24 Point Two-Letter Faces

ADJUSTABLE TRIANGULAR SHELF STYLE

Recessed 18 Points



.140" high alignment

Part Numbers		
Name of Part	30-em Mold	42-em Mold
Mold, Assembled	U-3950	U-3964
Mold Cap	U-3949	U-3963
Mold Body	U-1645	U-1599
Right-Hand Liner	U- 327	U- 327
Left-Hand Liner	U-3157	U-3157
Mold Liner Block	U-3155D	U-3155D

Use 6 point liners for 24 point slug

NEWSPAPER HEADLETTER SHELF STYLE

Recessed 18 Points



.140" high alignment

Part Numbers		
Name of Part	30-em Mold	42-em Mold
Mold, Assembled	U-3987	U-3993
Mold Cap	U-3990	U-3996
Mold Body	U-1645	U-1599
Right-Hand Liner	U- 327	U- 327
Left-Hand Liner	*U-3157	*U-3157
Mold Liner Block	*U-3155D	*U-3155D

For 18 and 24 Point Two-Letter Advertising Figures

ADJUSTABLE TRIANGULAR SHELF STYLE R CAP

Recessed 12 Points



.140" high alignment

Part Numbers		
Name of Part	30-em Mold	42-em Mold
Mold, Assembled	U-4616R	U-4617R
Mold Cap	U-3154R	U-3213R
Mold Body	U-1645	U-1599
Right-Hand Liner	U- 327	U- 327
Left-Hand Liner	U-3157	U-3157
Mold Liner Block	U-3155R	U-3155R

Range of Liners for R Caps

Liner Size	Slug Size	Liner Size	Slug Size
6 point for 18 point		10 point for 22 point	
7 point for 19 point		11 point for 23 point	
8 point for 20 point		12 point for 24 point	
9 point for 21 point			

The R cap may also be used to cast straight matter work of 18 and 24 point, using 18 and 24 point two-letter headletter matrices only and using 6 and 12 point liners.

NEWSPAPER HEADLETTER SHELF STYLE R CAP

Recessed 12 Points

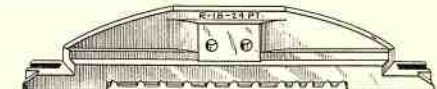

.140" high alignment

Part Numbers		
Name of Part	30-em Mold	42-em Mold
Mold, Assembled	U-4639R	U-4640R
Mold Cap	U-2467R	U-3966R
Mold Body	U-1645	U-1599
Right-Hand Liner	U- 327	U- 327
Left-Hand Liner	*U-3157	*U-3157
Mold Liner Block	*U-3155R	*U-3155R

R Cap Advertising Figure Work

Adv. Figure	Kind of Work
60 point	two lines 24 point
48 point	two lines 24 point
42 point	two lines 24 point
42 point	two lines 18 point

For use with 18 and 24 point Two-Letter Headletter Matrices only

All matrices in the Auxiliary Position
Maximum Overhang..... 26 points

*Mold Liner Block used only for measures up to 27 ems on 30-em mold, and up to 39 ems on 42-em mold. Either Left-Hand Liner U-328 or U-3157 can be used to cast maximum length of slug on 30 or 42-em mold.

See pages 32 to 38 for examples of advertising figure work

Molds for High Cap Accent Faces

When ordering molds for use with high cap accent matrices for outstanding machines, which machines have not previously been equipped with molds for high cap accent matrices, it is necessary to change a pin or pins in the first-elevator alignment stop bar and in the first-elevator vise automatic stop.

Therefore, when ordering molds for high cap accent matrices, please specify what molds are now on the machine, what molds will be replaced by the high cap accent molds, serial number of the machine, and what molds, if any, will be used on the machine in addition to the molds for the high cap accent matrices.

With this information we can advise what pins are needed and how to install them.

When a new machine is shipped from the factory, and it is equipped with molds for use with high cap accent matrices, the correct pins for the first-elevator alignment stop bar and the first-elevator vise automatic stop are on the machine.

For 5 to 12 Point High Cap Accent Faces

UNIVERSAL CAP

Solid Slugs



.020" alignment

Part Numbers

Name of Part	30-em Mold	42-em Mold
Mold, Assembled	U-1100	U-1600
Mold Cap	U- 329	U-1468
Mold Body	U-1101	U-1597
Right-Hand Liner	U- 327	U- 327
Left-Hand Liner	U- 328	U- 328

Range of Liners for Universal Cap

Size of Face	Size of Liner	Size of Slug
5 point	7 point	7 point
6 point	8 point	8 point
7 point	9 point	9 point
8 point	10 point	10 point
9 point	11 point	11 point
10 point	12 point	12 point
11 point	13 point	13 point
12 point	14 point	14 point

For 9 to 14 Point High Cap Accent Faces

OLD-STYLE B CAP

Recessed 6 Points

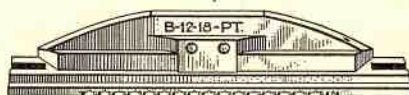

.020" alignment

Part Numbers

Name of Part	30-em Mold	42-em Mold
Mold, Assembled	U-1100B	U-1600B
Mold Cap	U- 329B	U-1468B
Mold Body	U-1101	U-1597
Right-Hand Liner	U- 327	U- 327
Left-Hand Liner	U- 328	U- 328

Range of Liners for B Cap

Size of Face	Size of Liner	Size of Slug
9 point	5 point	11 point
10 point	6 point	12 point
11 point	7 point	13 point
12 point	8 point	14 point
13 point	9 point	15 point
14 point	10 point	16 point

For 7 to 14 Point High Cap Accent Faces

OLD-STYLE A CAP

Recessed 4 Points

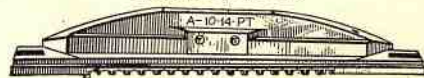

.020" alignment

Part Numbers

Name of Part	30-em Mold	42-em Mold
Mold, Assembled	U-1100A	U-1600A
Mold Cap	U- 329A	U-1468A
Mold Body	U-1101	U-1597
Right-Hand Liner	U- 327	U- 327
Left-Hand Liner	U- 328	U- 328

Range of Liners for A Cap

Size of Face	Size of Liner	Size of Slug
7 point	5 point	9 point
8 point	6 point	10 point
9 point	7 point	11 point
10 point	8 point	12 point
11 point	9 point	13 point
12 point	10 point	14 point
13 point	11 point	15 point
14 point	12 point	16 point

Molds for Normal High Cap Accent Faces

When ordering molds for use with normal high cap accent matrices for outstanding machines, which machines have not previously been equipped with molds for casting normal high cap accent matrices, it is necessary to change a pin or pins in the first-elevator alignment stop bar and in the first-elevator vise automatic stop.

Therefore, when ordering molds for normal high cap accent matrices, please specify what molds are now on the machine, what molds will be replaced by the normal high cap accent molds, serial number of the machine, and what molds, if any, will be used on the machine in addition to the molds for the normal high cap accent matrices.

With this information we can advise what pins are needed and how to install them.

When a new machine is shipped from the factory, and it is equipped with molds for use with normal high cap accent matrices, the correct pins for the first-elevator alignment stop bar and the first-elevator vise automatic stop are on the machine.

For 5 to 13 Point Normal High Cap Accent Faces

UNIVERSAL CAP

Solid Slugs

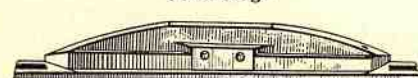

.012" alignment

Part Numbers

Name of Part	30-em Mold	42-em Mold
Mold, Assembled	U-2331	U-3956
Mold Cap	U- 329	U-1468
Mold Body	U-2332	U-3957
Right-Hand Liner	U- 327	U- 327
Left-Hand Liner	U- 328	U- 328

Range of Liners for Universal Cap

Size of Face	Size of Liner	Size of Slug
5 point	6 point	6 point
6 point	7 point	7 point
7 point	8 point	8 point
8 point	9 point	9 point
9 point	10 point	10 point
10 point	11 point	11 point
11 point	12 point	12 point
12 point	13 point	13 point
13 point	14 point	14 point

For 8 to 13 Point Normal High Cap Accent Faces

OLD-STYLE A CAP

Recessed 4 Points

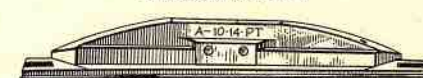

.012" alignment

Part Numbers

Name of Part	30-em Mold	42-em Mold
Mold, Assembled	U-2331A	U-3956A
Mold Cap	U- 329A	U-1468A
Mold Body	U-2332	U-3957
Right-Hand Liner	U- 327	U- 327
Left-Hand Liner	U- 328	U- 328

ADJUSTABLE TRIANGULAR SHELF STYLE A CAP

Recessed 4 Points

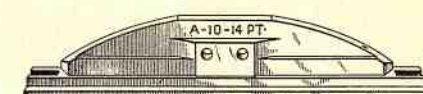

.012" alignment

Part Numbers

Name of Part	30-em Mold	42-em Mold
Mold, Assembled	U-3881A	U-3958A
Mold Cap	U-3154A	U-3213A
Mold Body	U-2332	U-3957
Right-Hand Liner	U- 327	U- 327
Left-Hand Liner	U-3157	U-3157
Mold Liner Block	U-3155A	U-3155A

Molds for Small Cap and Low Cap Accent Faces

Low cap accents from 5 to 36 points are used like the regular matrices of these point sizes. They cast on slugs of the same point sizes as the matrices and use the various caps with body U-61.

Small cap accents from 5 to 60 points cast on the same molds as regular matrices in these sizes. They cast on slugs of the same point size as the matrices.

Range of Liners for A Caps

Size of Face	Size of Liner	Size of Slug
8 point	5 point	9 point
9 point	6 point	10 point
10 point	7 point	11 point
11 point	8 point	12 point
12 point	9 point	13 point
13 point	10 point	14 point

**For 10 to 16 Point
Normal High Cap Accent Faces**

OLD-STYLE B CAP

Recessed 6 Points

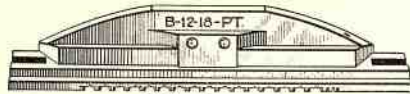

.012" alignment

Part Numbers

Name of Part	30-em Mold	42-em Mold
Mold, Assembled	U-2331B	U-3956B
Mold Cap	U-329B	U-1468B
Mold Body	U-2332	U-3957
Right-Hand Liner	U-327	U-327
Left-Hand Liner	U-328	U-328

**ADJUSTABLE TRIANGULAR
SHELF STYLE B CAP**

Recessed 6 Points

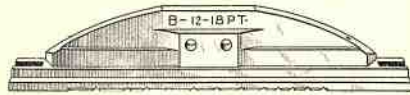

.012" alignment

Part Numbers

Name of Part	30-em Mold	42-em Mold
Mold, Assembled	U-3881B	U-3958B
Mold Cap	U-3154B	U-3213B
Mold Body	U-2332	U-3957
Right-Hand Liner	U-327	U-327
Left-Hand Liner	U-3157	U-3157
Mold Liner Block	U-3155B	U-3155B

Range of Liners for B Caps

Size of Face	Size of Liner	Size of Slug
10 point	5 point	11 point
11 point	6 point	12 point
12 point	7 point	13 point
13 point	8 point	14 point
14 point	9 point	15 point
15 point	10 point	16 point
16 point	11 point	17 point

**For 18 and 20 Point
Normal High Cap Accent Faces**

**ADJUSTABLE TRIANGULAR
SHELF STYLE C CAP**

Recessed 12 Points



.028" alignment

Part Numbers

Name of Part	30-em Mold	42-em Mold
Mold, Assembled	U-3440C	U-3960C
Mold Cap	U-3154C	U-3213C
Mold Body	U-2349	U-3959
Right-Hand Liner	U-327	U-327
Left-Hand Liner	U-3157	U-3157
Mold Liner Block	U-3155C	U-3155C

Range of Liners for C Cap

Size of Face	Size of Liner	Size of Slug
18 point	8 point	20 point
20 point	10 point	22 point

**For 24 and 28 Point
Normal High Cap Accent Faces**

**ADJUSTABLE TRIANGULAR
SHELF STYLE D CAP**

Recessed 18 Points

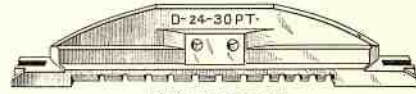

.028" alignment

Part Numbers

Name of Part	30-em Mold	42-em Mold
Mold Assembled	U-3440D	U-3960D
Mold Cap	U-3154D	U-3213D
Mold Body	U-2349	U-3959
Right-Hand Liner	U-327	U-327
Left-Hand Liner	U-3157	U-3157
Mold Liner Block	U-3155D	U-3155D

Range of Liners for D Cap

Size of Face	Size of Liner	Size of Slug
24 point	8 point	26 point
28 point	12 point	30 point

**For 28, 30 and 34 Point
Normal High Cap Accent Faces**

**ADJUSTABLE TRIANGULAR
SHELF STYLE E CAP**

Recessed 24 Points

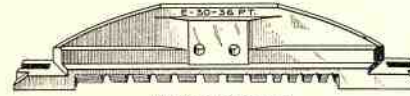

.028" alignment

Part Numbers

Name of Part	30-em Mold	42-em Mold
Mold, Assembled	U-3440E	U-3960E
Mold Cap	U-3154E	U-3213E
Mold Body	U-2349	U-3959
Right-Hand Liner	U-327	U-327
Left-Hand Liner	U-3157	U-3157
Mold Liner Block	U-3155E	U-3155E

Range of Liners for E Cap

Size of Face	Size of Liner	Size of Slug
28 point	6 point	30 point
30 point	8 point	32 point
34 point	12 point	36 point

**For 34 and 36 Point
Normal High Cap Accent Faces**

**ADJUSTABLE TRIANGULAR
SHELF STYLE P CAP**

Recessed 30 Points

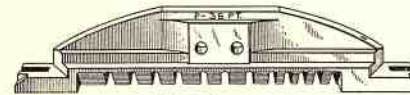

.028" alignment

Part Numbers

Name of Part	30-em Mold	42-em Mold
Mold, Assembled	U-3440P	U-3960P
Mold Cap	U-3154P	U-3213P
Mold Body	U-2349	U-3959
Right-Hand Liner	U-327	U-327
Left-Hand Liner	U-3157	U-3157
Mold Liner Block	U-3155P	U-3155P

Range of Liners for P Cap

Size of Face	Size of Liner	Size of Slug
34 point	6 point	36 point
36 point	8 point	38 point

**For 42, 48 and 60 Point
Normal High Cap Accent Faces**

CAPS ONLY

60 point caps cast on 48 point slug

**ADJUSTABLE TRIANGULAR
SHELF STYLE Q CAP**

Recessed 36 Points

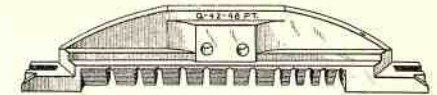

.168" alignment

Part Numbers

Name of Part	30-em Mold	42-em Mold
Mold, Assembled	U-3250Q	U-3251Q
Mold Cap	U-3154Q	U-3213Q
Mold Body	U-2063	U-2326
Right-Hand Liner	U-327	U-327
Left-Hand Liner	U-3157	U-3157
Mold Liner Block	U-3155Q	U-3155Q

Range of Liners for Q Cap

Size of Face	Size of Liner	Size of Slug
42 point	6 point	42 point
48 point	12 point	48 point
60 point	12 point	48 point

**For 18 Point Two-Letter
Normal High Cap Accent Faces**

**ADJUSTABLE TRIANGULAR
SHELF STYLE**

Recessed 12 Points



Part Numbers

Name of Part	30-em Mold	42-em Mold
Mold, Assembled	U-4381	U-4635
Mold Cap	U-3947	U-3969
Mold Body	U-4194	U-4195
Right-Hand Liner	U-327	U-327
Left-Hand Liner	U-3157	U-3157
Mold Liner Block	U-3155C	U-3155C

Use 6 point liners only for 18 point slug

For 18 and 24 Point Two-Letter
Normal High Cap Accent Faces

**ADJUSTABLE TRIANGULAR
SHELF STYLE**

Recessed 12 Points



Part Numbers

Name of Part	30-em Mold	42-em Mold
Mold, Assembled	U-4380	U-4636
Mold Cap	U-3951	U-3971
Mold Body	U-4194	U-4195
Right-Hand Liner	U- 327	U- 327
Left-Hand Liner	U-3157	U-3157
Mold Liner Block	U-3155C	U-3155C

Range of Liners for 18 and 24 Point Cap
6 point liner for 18 point slug
12 point liner for 24 point slug

For 24 Point Two-Letter
Normal High Cap Accent Faces

**ADJUSTABLE TRIANGULAR
SHELF STYLE**

Recessed 18 Points



Part Numbers

Name of Part	30-em Mold	42-em Mold
Mold, Assembled	U-4382	U-4637
Mold Cap	U-3949	U-3963
Mold Body	U-4194	U-4195
Right-Hand Liner	U- 327	U- 327
Left-Hand Liner	U-3157	U-3157
Mold Liner Block	U-3155D	U-3155D

Use 6 point liners only for 24 point slug

SPECIAL MOLDS

LOW SLUG MOLDS

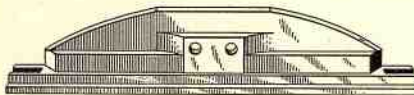

Part Numbers

Name of Part	30-em Mold	42-em Mold
Mold, Assembled	U-1030	U-1750
Mold Cap	U-1036	U-1748
Mold Body	U-1031	U-1749
Right-Hand Liner	U-1032	U-1032
Left-Hand Liner	U-1033	U-1033

Range of Liners for Low-Slug Mold

Liner Size	Slug Size	Liner Size	Slug Size
5 point	for 5 point	10 point	for 10 point
6 point	for 6 point	11 point	for 11 point
7 point	for 7 point	12 point	for 12 point
8 point	for 8 point	13 point	for 13 point
9 point	for 9 point	14 point	for 14 point

The low slug mold is for casting leads or spacing material .754" high from 5 to 14 points and is used in connection with matrix slides U-441 for 13 ems or less, U-1257 from 13½ ems to 30 ems, and U-1817 for 30½ ems to 42 ems.

RIBBLESS MOLDS

Solid Slug



Part Numbers

Name of Part	30-em Mold	42-em Mold
Mold, Assembled	U-2242	U-2243
Mold Cap	U-2238	U-2239
Mold Body	U- 61	U-1489
Right-Hand Liner	U-2233	U-2233
Left-Hand Liner	U-2234	U-2234

Range of Liners for Ribbles Mold

Liner Size	Slug Size	Liner Size	Slug Size
5 point	for 5 point	9 point	for 9 point
6 point	for 6 point	10 point	for 10 point
7 point	for 7 point	11 point	for 11 point
8 point	for 8 point	12 point	for 12 point

**MOLDS FOR
INTERTYPE SIX-POCKET DISK**

The molds for the six-mold disk are made of special mold steel, which is carefully heat-treated and hardened, to insure durability and accuracy in continuous use.

All parts of the mold are ground within very close limits, resulting in a high degree of accuracy in the alignment and dimensions of the parts.

The finished molds are put through a special process which produces a beautiful ebony finish on the steel. This finish penetrates the metal and protects it from moisture and helps to prevent the formation of rust and other foreign substances on the mold.

The molds applied to the six-pocket disk are of an entirely new type. They are short and compact—and thus are less subject to distortion. They are made in two styles.

Liner Insert Style

The liner insert style of mold, Fig. 9, is composed of three parts; namely, a mold cap, a liner insert and a mold body. The length and point size of line is cut out of the liner insert: Inserts are made for casting solid slugs from 5 to 14 point and recessed slugs from 10 to 14 point.

Only one point size and length can be cast with an insert.

Always specify the point size and length of slug when ordering liner inserts or molds assembled with liner inserts.

Lengths other than 12 ems, 24½ ems or 30 ems are considered special.

Liner inserts are interchangeable and are recommended for types of work where the point size or length of slugs or both change from time to time.

Liner inserts are suitable for casting overhanging characters up to 30 point in size.

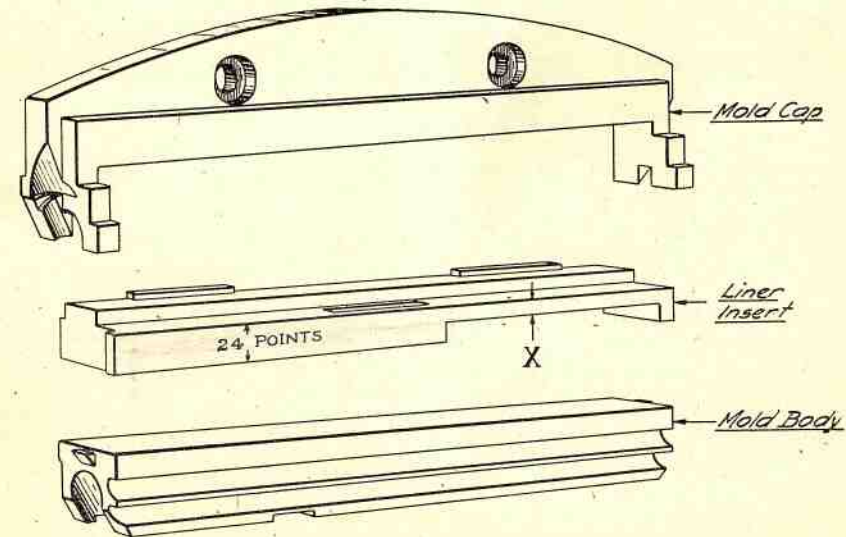

Fig. 9. A Liner Insert Mold Showing Component Parts

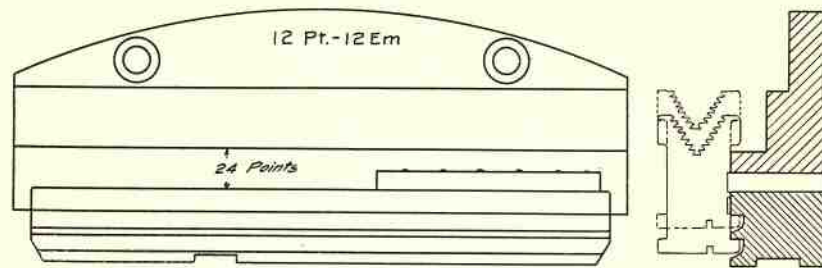

Fig. 10. A Linerless Mold for Solid Slugs

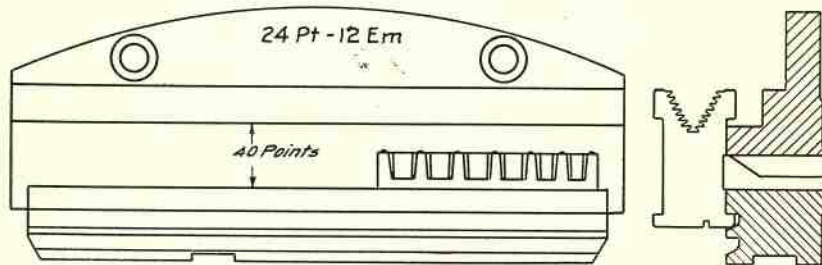

Fig. 11. A Linerless Mold for Recessed Slugs

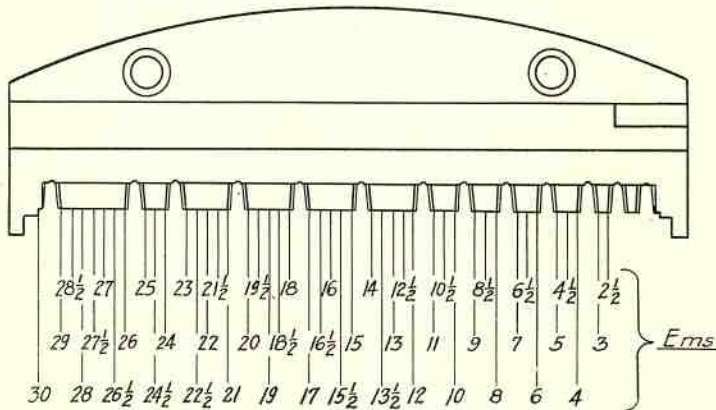

Fig. 12. Standard Rib Arrangement for 30-em recessed six-pocket mold, showing length of slug which can be cast.

Linerless Style

The linerless style of mold, Fig. 10, is composed of two parts; namely, a mold cap and a mold body. The length and point size of line is cut out of the mold cap proper.

Only one point size and length can be cast with a mold cap.

Always specify the point size and length of slug when ordering mold caps or molds (linerless) assembled.

Lengths other than 12 ems, 24 1/2 ems or 30 ems are considered special.

Mold caps U-4052, U-4274, U-4275, U-4276, U-4277 and U-4278 are interchangeable with any standard mold body U-4051.

Mold caps U-4279 and U-4054 are interchangeable with any high alignment (.140") mold body U-4053.

For 5 to 14 Point Faces

LINER INSERT STYLE

Solid Slugs

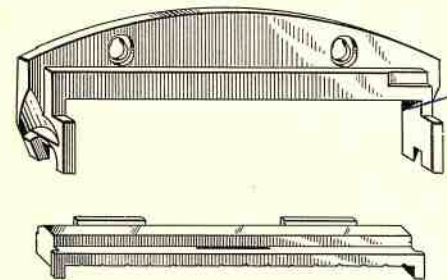

LINERLESS STYLE

Solid Slugs

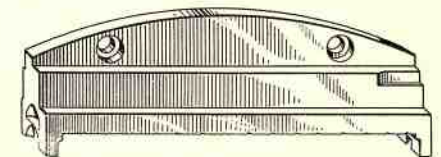

Part Numbers

Name of Part	
Mold, Assembled	U-4050
Mold Cap	U-4052
Mold Body	U-4051

Part Numbers

Name of Part	
Mold, Assembled with Liner Insert	U-4081
Mold, Assembled without Liner Insert	U-4078
Mold Cap	U-4076
Mold Body	U-4051
Liner Insert, Solid Slugs	U-4077

Range of Advertising Figure Work

By using the proper liner inserts or corresponding linerless mold cap, the following overhang casting may be done on these caps:

Adv. Figure	Kind of Work
30 point	three lines of 8 point
30 point	two lines of 12 point
24 point	two lines of 10 point
24 point	two lines of 9 point
24 point	three lines of 8 point
24 point	three lines of 7 point
18 point	two lines of 8 point
18 point	three lines of 5 point

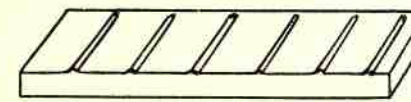

5 to 14 point solid slug

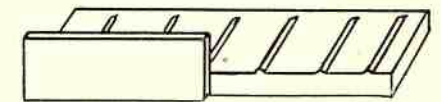

5 to 14 point solid slug with overhanging characters up to 30 point

See pages 32 to 38 for examples of advertising figure work

For 10, 12 or 14 Point Faces

LINER INSERT STYLE

Recessed Slugs

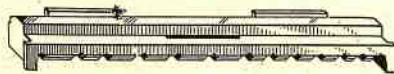
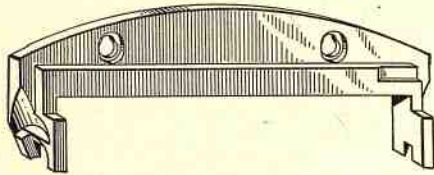

Part Numbers

Name of Part	
Mold, Assembled with Liner Insert	U-4082
Mold, Assembled without Liner Insert	U-4078
Mold Cap	U-4076
Mold Body	U-4051
Liner Insert, Recessed Slugs	U-4079

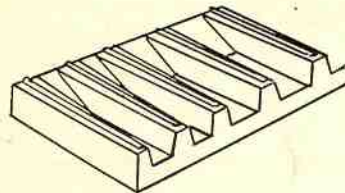

Recessed slug for 10, 12 or 14 point

LINERLESS STYLE

Recessed Slugs

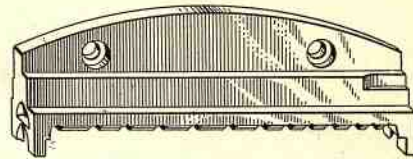

Part Numbers

Name of Part	
Mold, Assembled	U-4285
Mold Cap	U-4274
Mold Body	U-4051

Range of Advertising Figure Work

By using the proper liner insert or corresponding linerless mold cap, the following overhang casting may be done on these caps:

Adv. Figure	Kind of Work
30 point	two lines of 12 point
24 point	two lines of 10 point

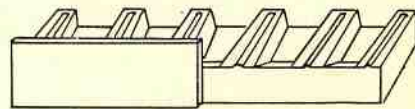

Recessed slug for 10, 12 or 14 point with overhanging characters up to 30 point

See pages 32 to 38 for examples of advertising figure work

THE INTERTYPE SIX-MOLD DISK provides for six different sizes of slugs in any measures up to 30 ems and any body sizes from 5 to 48 point, all quickly available to the operator from his position at the keyboard. It eliminates a great deal of changing of molds and mold liners, thus effecting a substantial increase of type production. Outstanding features include the fact that there are no restrictions as to slug lengths. Intertype's six-pocket disk accommodates six full-length 30-em molds. Another feature is automatic ejector blade selection, in coordination with the mold changes. When the operator shifts from one mold to another, the proper ejector blade for the mold selected is brought into operating position automatically. Centralized control of mold and ejector blade selection is provided in a single operating handle.

For 16, 18 and 24 Point One-Letter Faces

RECESSED LINERLESS TRIANGULAR SHELF STYLE

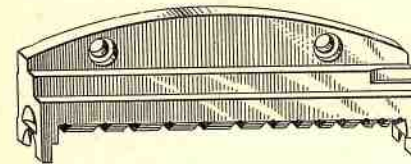

Part Numbers

Name of Part	
Mold, Assembled	U-4270
Mold Cap	U-4275
Mold Body	U-4051

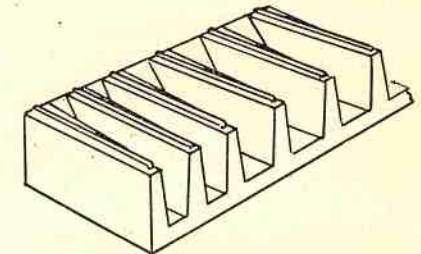

Recessed slug for 16, 18 or 24 point

Range of Advertising Figure Work

By using the proper mold cap, the following overhang casting may be done:

Adv. Figure	Kind of Work
42 point	two lines of 18 point
36 point	two lines of 16 point

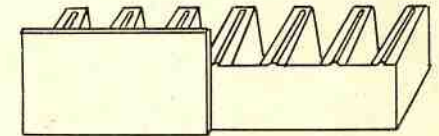

Recessed slug for 16, 18 or 24 point one-letter faces with overhanging characters up to 42 point.

For 16, 18 and 24 Point Two-Letter Headletter Faces

RECESSED LINERLESS TRIANGULAR SHELF STYLE
.140" High Alignment

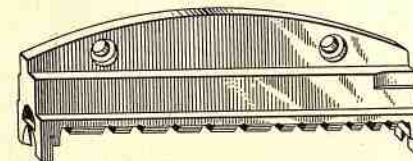

Part Numbers

Name of Part	
Mold, Assembled	U-4055
Mold Cap	U-4054
Mold Body	U-4053

For 30 or 36 Point Faces

RECESSED LINERLESS TRIANGULAR SHELF STYLE

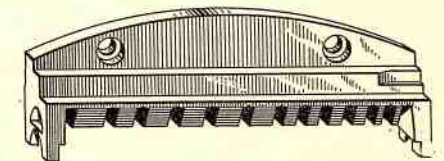

Part Numbers

Name of Part	
Mold, Assembled	U-4271
Mold Cap	U-4276
Mold Body	U-4051

See pages 32 to 38 for examples of advertising figure work

For 42, 48 or 60 Point Faces

RECESSED LINERLESS TRIANGULAR SHELF STYLE

.140" High Alignment

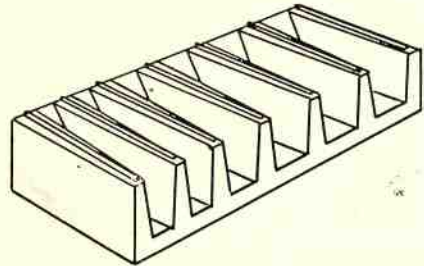
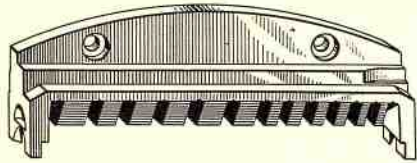

Recessed slug for 42, 48 or 60 point

Part Numbers

Name of Part	
Mold, Assembled	U-4080
Mold Cap	U-4279
Mold Body	U-4053

By using the proper mold cap, the following sizes may be cast together on one slug (not overhang).

- 60 pt. with 36 pt. one-letter on 48 pt. slug
- 60 pt. with 30 pt. one-letter on 48 pt. slug
- 60 pt. with 24 pt. one-letter on 48 pt. slug
- 60 pt. with 18 pt. one-letter on 48 pt. slug
- 48 pt. with 36 pt. one-letter on 48 pt. slug
- 48 pt. with 30 pt. one-letter on 48 pt. slug
- 48 pt. with 24 pt. one-letter on 48 pt. slug
- 48 pt. with 18 pt. one-letter on 48 pt. slug
- 42 pt. with 24 pt. one-letter on 42 pt. slug
- 42 pt. with 18 pt. one-letter on 42 pt. slug

For Advertising Figures up to 42 Point

RECESSED LINERLESS TRIANGULAR SHELF STYLE

Recessed Slug, 10, 12 or 14 Point

Part Numbers

Name of Part	
Mold, Assembled	U-4273
Mold Cap	U-4278
Mold Body	U-4051

Range of Advertising Figure Work

By using the proper mold cap, the following overhang casting may be done:

Adv. Figure	Kind of Work
42 point.....	three lines of 12 point
36 point.....	two lines of 14 point
36 point.....	three lines of 10 point
30 point.....	two lines of 12 point
24 point.....	two lines of 10 point

This mold may also be used to cast straight matter work of 10, 12 or 14 point (auxiliary position) by using the proper mold cap.

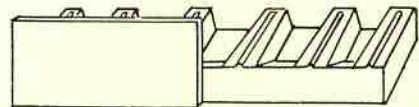
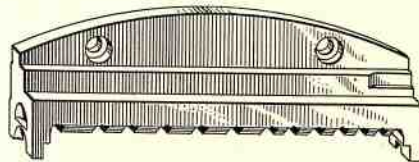

Recessed slug for 10, 12 or 14 point with overhanging characters up to 42 point

See pages 32 to 38 for examples of advertising figure work

For Advertising Figures up to 42 Point

LINERLESS STYLE

Solid Slug, 5 to 14 Point

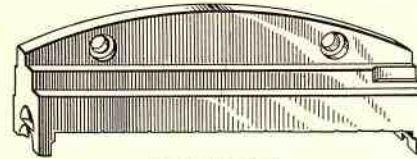

Part Numbers

Name of Part	
Mold, Assembled	U-4272
Mold Cap	U-4277
Mold Body	U-4051

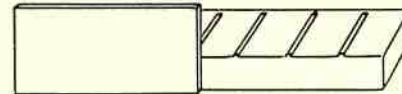

Solid slug for 5 to 14 point with overhanging characters up to 42 point

Range of Advertising Figure Work

By using the proper mold cap, the following overhang casting may be done:

Adv. Figure	Kind of Work
42 point.....	three lines of 12 point
42 point.....	four lines of 9 point
42 point.....	six lines of 6 point
42 point.....	five lines of 7 point
36 point.....	three lines of 10 point
36 point.....	five lines of 6 point
30 point.....	two lines of 12 point
30 point.....	three lines of 8 point
30 point.....	four lines of 6 point
24 point.....	two lines of 10 point
24 point.....	two lines of 9 point
24 point.....	three lines of 7 point
24 point.....	four lines of 5 point
18 point.....	two lines of 8 point
18 point.....	three lines of 5 point
14 point.....	two lines of 6 point
12 point.....	two lines of 5 point

This mold may also be used to cast straight matter work of 5 to 14 point (auxiliary position) by using the proper mold cap.

For Advertising Figures up to 60 Point

RECESSED LINERLESS TRIANGULAR SHELF STYLE

.140" High Alignment

For use with 18 and 24 point two-letter headletter matrices *only*.

Recessed Slug, 18 or 24 Points

Range of Advertising Figure Work

By using the proper mold cap, the following overhang casting may be done:

Adv. Figure	Kind of Work
60 point.....	two lines of 24 point
48 point.....	two lines of 24 point
42 point.....	two lines of 24 point
42 point.....	two lines of 18 point

This mold may also be used to cast straight matter work of 18 or 24 point using 18 and 24 point two-letter headletter matrices *only* and using the proper mold cap.

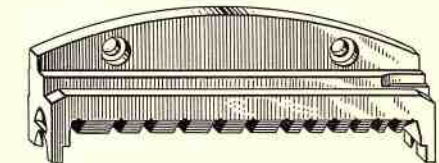

Part Numbers

Name of Part	
Mold, Assembled	U-4542
Mold Cap	U-4543
Mold Body	U-4053

See pages 32 to 38 for examples of advertising figure work

ADVERTISING FIGURE WORK

The possible variations of so-called Grocery Store work are practically unlimited. However, we have, on the following pages, illustrated a few typical examples of this type of composition which may be cast on Intertype molds.

All of these examples were set from the keyboard of an Intertype. Every specimen shown is cast on full-measure slugs. No cut-in whatsoever was used.

The great majority of Grocery Store work makes use of the overhang cast. The overhang, or portion which exceeds the slug size, casts against the face of the mold cap lip and produces a slug which looks like this:



The second slug is then cast. In addition to forming a second line of type, it serves as a support for one-half of the overhanging portion of the first slug:

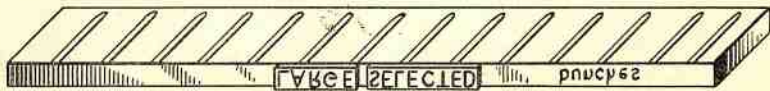

The third line is then cast. In addition to forming a third line of type, it serves as a support for the remaining half of the overhanging portion of the first slug:



When these three slugs are fitted together, they look like this:



and print like this:

CELEBRATE GARDEN FRESH
LARGE SELECTED
CRISP HEARTS **2** bunches **.11**

In addition to the overhang method of casting Grocery Store work, a great deal of this type of advertising is now set on one slug. This is accomplished by the use of alignment combinations. Specimens 24, 26, 28, 29, 30, 32, 33, 34, 35, 37 and 38 are examples of this style. All of these specimens are cast on one slug—no overhang and no cut-in being used.

No. 1

LACE CLOTHS. Fragile looking but strongly made of firm cotton. Size 72x90. Special at **\$1.79**

OCTAGON SOAP The All Purpose Household Soap **3 Large Cakes 10c**

Two lines of 5 Point Regal with Bold with 12 Point Vogue Extra Bold Condensed. Mold caps: Four-Mold Disk: Universal, page 10; F, page 15; Six-Mold Disk: U-4277, page 31.

No. 2

SHEET BLANKETS. Seconds. First quality would be 59c. These soft plaid cotton sheet blankets are just right for summer. Special **49c**

CLEANSER OLD DUTCH Goes further Don't scratch **3 No. 2 Large Cans 20c**

Three lines of 5 Point Regal with Bold with 18 Point Vogue Extra Bold Condensed. Mold caps: Four-Mold Disk: F, page 15; H, page 16; Six-Mold Disk: U-4052, page 27; U-4076, page 27; U-4277, page 31.

No. 3

WOMEN'S WHITE HATS. Many copies of expensive types. Wide brim picture styles, close fitting rayon turbans. Very summery and becoming. For Misses and Matrons **98c**

HAMS Hormel's Delicious Smoked or Sugar Cured Quality Guaranteed Whole or Half per lb **27c**

Four lines of 5 Point Regal with Bold with 24 Point Vogue Extra Bold Condensed. Mold caps: Four-Mold Disk: H, page 16; Six-Mold Disk: U-4277, page 31.

No. 4

COTTAGE CURTAINS. New style curtain sets for summer bungalows or kitchens. In green, gold, blue or black figured with matching fringe **49c**

SALT American House Regular or Iodized For Table and Kitchen Use **2 large size bags for 18c**

Four lines of 6 Point Regal No. 1 with Bold with 24 Point Vogue Extra Bold Condensed. Mold caps: Four-Mold Disk: H, page 16.

No. 5

HANDBAGS. Large roomy styles or trim tailored ones **39c**

SAUCE Spanish Style **2 cans for 18c**

Two lines of 9 Point Regal with Bold with 24 Point Vogue Extra Bold Condensed. Mold caps: Four-Mold Disk: F, page 15; Six-Mold Disk: U-4052 and U-4076, page 27; U-4277, page 31.

No. 6

MATTRESS COVERS. Printed percale quilt covers. Well made, with buttons. **89c**

GRAPEFRUIT Popular Brand Fancy Quality **2 large cans 13c**

Two lines of 6 Point Regal No. 1 with Bold with 14 Point Vogue Extra Bold Condensed. Mold caps: Four-Mold Disk: Universal, page 10; F, page 15; Six-Mold Disk: U-4277, page 31.

No. 7

SWIM TRUNKS. Wool trunks with belts. All sizes and colors **69c**

CRACKERS Milk or Graham **2 1-lb boxes 9c**

Two lines of 8 Point Regal No. 1 with Bold with 18 Point Vogue Extra Bold Condensed. Mold caps: Four-Mold Disk: Universal, page 10; F, page 15; H, page 16; M, page 15; N, page 10; Six-Mold Disk: U-4052, page 27; U-4076, page 27; U-4277, page 31.

No. 8

BEADED BAGS. Regularly \$1.59. Styles with zippers and frame tops in multicolored effects and solids **59c**

SOAP For Household or Toilet use, your choice of all leading brands. **5c**

Three lines of 6 Point Regal No. 1 with Bold with 24 Point Vogue Extra Bold Condensed. Mold caps: Four-Mold Disk: M, page 15.

No. 9

WOMEN'S GLOVES. Silk and cotton fabric or doeskin-tanned lambskin. Sizes 6 to 8 in group. **39c**

CIDER Pure Apple GAL. The Native American Drink **25c**

Three lines of 7 Point Regal No. 1 with Bold with 24 Point Vogue Extra Bold Condensed. Mold caps: Four-Mold Disk: F, page 15; H, page 16; I, page 17; M, page 15; Six-Mold Disk: U-4052, page 27; U-4076, page 27; U-4277, page 31.

No. 10

PLAYSUITS. Cool cotton summer suits for children **58c**

SHRIMP LIBBY'S Royal Brand **17c**

Two lines of 10 Point Regal with Bold with 24 Point Vogue Extra Bold Condensed. Mold caps: Four-Mold Disk: Universal, page 10; F, page 15; G, page 16; M, page 15; N, page 10; Six-Mold Disk: U-4052, page 27; U-4076, page 27; U-4274, page 28; U-4277, page 31; U-4278, page 30.

No. 11

BEACH BAGS. Regularly 98c. Sturdy canvas covered bags in solid colors and combinations **79c**

Catsup American House Select Quality Large 14-oz. bottle **7c**

Three lines of 8 Point Regal No. 1 with Bold with 24 Point Vogue Extra Bold Condensed. Mold caps: Four-Mold Disk: H, page 16; Six-Mold Disk: U-4052, page 27; U-4076, page 27.

No. 12

WIZ RUG CLEANER. 15-oz. can regularly \$1. Makes rug cleaning easy. Foamy suds take dirt from rug without taking it from floor **79c**

PEAS Highest Quality Fresh Packed **3** No. 2 tall cans for **22c**

Four lines of 6 Point Regal No. 1 with Bold with 30 Point Vogue Extra Bold Condensed. Mold caps: Four-Mold Disk: I, page 17; Six-Mold Disk: U-4277, page 31.

No. 13

SANDALS. Colored and white cottons with leather or rubber soles. Shopworn **39c**

MILK Eagle Evaporated per can **5c**

Three lines of 10 Point Vogue with Bold with 36 Point Vogue Extra Bold Condensed. Mold Caps: Four-Mold Disk: I, page 17; Six-Mold Disk: U-4277, page 31; U-4278, page 30.

No. 14

BOYS' SHIRTS. The complete summer outfit. Polo shirts in cool summer cottons; green, blue and tan. In sizes 8 to 18. Wash shorts in cotton weaves with elastic sides and belts **.19**

HAM ARMOUR Quality or Squire's Boneless no waste PER LB. **.21**

Six lines of 6 Point Regal No. 1 with Bold with 42 Point Gothic No. 13 (headletter position). Mold caps: Four-Mold Disk: I, page 17; Six-Mold Disk: U-4277, page 31.

No. 15

CHINTZ PILLOWS. New, cotton filled pillows covered with floral patterns. Special sale this week **25c**

FLOUR Dependable Quality 24-lb sack **61c**

Three lines of 8 Point Vogue with Bold with 30 Point Vogue Extra Bold Condensed. Mold caps: Four-Mold Disk: H, page 16; Six-Mold Disk: U-4052, page 27; U-4076, page 27; U-4277, page 31.

No. 16

MEN'S SWEATERS. Samples and closeouts. Formerly \$1.88. Coat style with slide fasteners or buttons. Three-tone combinations. Sizes from 36 to 44 **79c**

VEAL ARMOUR'S Genuine Milk Fed Leg or Shoulder Rolls **22c**

Five lines of 6 Point Regal No. 1 with Bold with 30 Point Vogue Extra Bold Condensed. Mold caps: Four-Mold Disk: I, page 17; Six-Mold Disk: U-4277, page 31.

No. 17

MOCCASINS. These heavy rubber soled moccasins are made with tough pliable uppers in brown and black and in sizes from 6 to 11. **.59**

TEA TETLEY'S Green Budget 1/2-pound package **.16**

Five lines of 7 Point Regal No. 1 with Bold with 42 Point Gothic No. 13 (headletter position). Mold caps: Four-Mold Disk: I, page 17; Six-Mold Disk: U-4277, page 31.

No. 18

TURBANS. Cotton mesh wrap-around turbans in white, pastel and darker colors. Neckwear Dept. **.19**

LUX Soap or Flakes 2 large size for **.16**

Four lines of 9 Point Regal with Bold with 42 Point Gothic No. 13 (headletter position). Mold caps: Four-Mold Disk: I, page 17; Six-Mold Disk: U-4277, page 31.

No. 19

SARDINES Packed in Oil or Mustard **3 large cans 19c**

Two lines of 12 Point Vogue Bold with Oblique with 30 Point Vogue Extra Bold. Mold caps: Four-Mold Disk: F, page 15; G, page 16; J, page 17; Six-Mold Disk: U-4052, page 27; U-4076, page 27; U-4274, page 28; U-4277, page 31; U-4278, page 30.

No. 20

RINSO SPECIAL FOR THURSDAY **2 large boxes .35**

Two lines of 14 Point Vogue Bold with Oblique with 36 Point Vogue Extra Bold. Mold caps: Four-Mold Disk: J, page 17; Six-Mold Disk: U-4278, page 30.

No. 21

LAMB Choicest Spring Legs, Chops or Shoulders **LB. .22**

Two lines of 16 Point Futura Medium with 36 Point Vogue Extra Bold. Mold caps: Four-Mold Disk: J, page 17; Six-Mold Disk: U-4275, page 29.

No. 22

POTATOES Fancy New Crop **10 lbs. 19c for**

Two lines of 18 Point Vogue Bold with 36 Point Vogue Extra Bold Condensed. Mold caps: Four-Mold Disk: C, page 11.

No. 23

CELERY GARDEN FRESH LARGE SELECTED CRISP HEARTS **2 bunches .11**

Three lines of 12 Point Vogue with Bold with 42 Point Gothic No. 13 (headletter position). Mold caps: Four-Mold Disk: I, page 17; Six-Mold Disk: U-4277, page 31; U-4278, page 30.

No. 24

Apples North American Supreme **2 lbs. 13^c**

One line of 18 Point Vogue Bold Condensed with 42 Point Vogue Extra Bold Condensed (not overhang).
Mold Caps: Four-Mold Disk: Q, page 14; Six-Mold Disk: U-4279, page 30.

No. 25

GRAPES Large Sweet
Seedless **2 lbs. .11**

Two lines of 18 Point Vogue Bold with 42 Point Gothic No. 13 (headletter position). Mold caps:
Four-Mold Disk: C, page 11; J, page 17; R, page 19; Six-Mold Disk: U-4275, page 20; U-4543, page 31.

No. 26

Apples Large Red Baldwins **3 lbs. 19^c**

One line of 24 Point Vogue Bold Condensed with 42 Point Vogue Extra Bold Condensed (not overhang).
Mold caps: Four-Mold Disk: Q, page 14; Six-Mold Disk: U-4279, page 30.

No. 27

Grapefruit Sunnybrook Brand **19^c**
2 large cans

Two lines of 24 Point Vogue Bold Condensed with 42 Point Vogue Extra Bold Condensed. Mold caps:
Four-Mold Disk: R, page 19; Six-Mold Disk: U-4543, page 31.

No. 28

Apples Large for Baking **2 lbs. 9^c**

One line of 30 Point Vogue Bold Condensed with 42 Point Vogue Extra Bold Condensed (not overhang).
Mold caps: Four-Mold Disk: Q, page 14; Six-Mold Disk: U-4279, page 30.

No. 29

BEANS Large Tender String **3 lbs. 18^c**

One line of 18 Point Vogue Bold Condensed with 48 Point Vogue Extra Bold Condensed (not overhang).
Mold caps: Four-Mold Disk: Q, page 14; Six-Mold Disk: U-4279, page 30.

No. 30

BEANS New Stringless **2 cans 12^c**

One line of 24 Point Vogue Bold Condensed with 48 Point Vogue Extra Bold Condensed (not overhang).
Mold caps: Four-Mold Disk: Q, page 14; Six-Mold Disk: U-4279, page 30.

No. 31

Pineapple Fancy Sliced
or Crushed **21^c**

Two lines of 24 Point Vogue Bold Condensed with 48 Point Vogue Extra Bold Condensed. Mold caps:
Four-Mold Disk: R, page 19; Six-Mold Disk: U-4543, page 31.

No. 32

BEANS Baked or Brown can **9^c**

One line of 30 Point Vogue Bold Condensed with 48 Point Vogue Extra Bold Condensed (not overhang).
Mold caps: Four-Mold Disk: Q, page 14; Six-Mold Disk: U-4279, page 30.

No. 33

BEANS Fresh Baked lb. **8^c**

One line of 36 Point Vogue Bold Condensed with 48 Point Vogue Extra Bold Condensed (not overhang).
Mold caps: Four-Mold Disk: Q, page 14; Six-Mold Disk: U-4279, page 30.

No. 34

PEARS Fresh Vacuum Packed **2** cans **17^c**

One line of 18 Point Vogue Bold Condensed with 60 Point Vogue Extra Bold Condensed (not overhang).
Mold caps: Four-Mold Disk: Q, page 14; Six-Mold Disk: U-4279, page 30.

No. 35

PEARS Large Sun Ripened lb. **10^c**

One line of 24 Point Vogue Bold Condensed with 60 Point Vogue Extra Bold Condensed (not overhang).
Mold caps: Four-Mold Disk: Q, page 14; Six-Mold Disk: U-4279, page 30.

No. 36

BREAD Fresh Baked Daily
Rye, White or Raisin **9^c**

Two lines of 24 Point Vogue Bold Condensed with 60 Point Vogue Extra Bold Condensed. Mold caps:
Four-Mold Disk: R, page 19; Six-Mold Disk: U-4543, page 31.

No. 37

PEARS Large Bartletts lb. **12^c**

One line of 30 Point Vogue Bold Condensed with 60 Point Vogue Extra Bold Condensed (not overhang).
Mold caps: Four-Mold Disk: Q, page 14; Six-Mold Disk: U-4279, page 30.

No. 38

PEARS 2 large cans **19^c**

One line of 36 Point Vogue Bold Condensed with 60 Point Vogue Extra Bold Condensed (not overhang).
Mold caps: Four-Mold Disk: Q, page 14; Six-Mold Disk: U-4279, page 30.